

**TECHNICAL MANUAL**

**OPERATOR'S, UNIT, AND DIRECT  
SUPPORT MAINTENANCE MANUAL  
INCLUDING REPAIR PARTS AND  
SPECIAL TOOLS LIST (RPSTL)  
FOR**

**TRICON CONTAINER  
MODEL ESETC-01  
NSN 8145-01-389-9184**

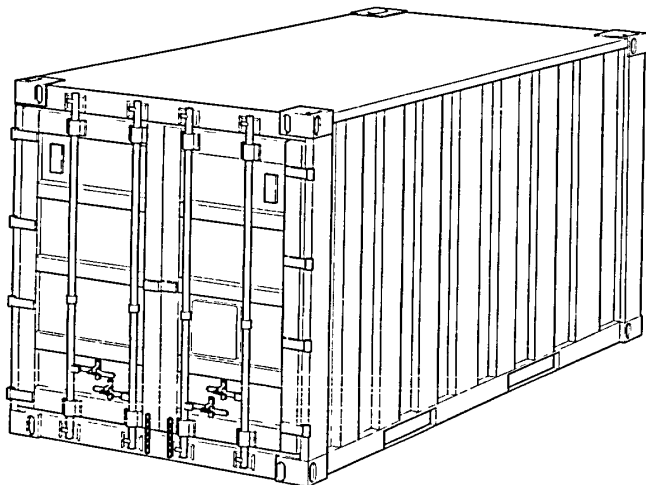

**DISTRIBUTION STATEMENT A:** Approved for public release; distribution is unlimited.

|   |             |
|---|-------------|
| <b>INTRODUCTION</b>                     | <b>1-1</b>  |
| <b>EQUIPMENT DESCRIPTION</b>            | <b>1-3</b>  |
| <b>PRINCIPLES OF OPERATION</b>          | <b>1-5</b>  |
| <b>OPERATING INSTRUCTIONS</b>           | <b>2-1</b>  |
| <b>OPERATION UNDER USUAL CONDITIONS</b> | <b>2-5</b>  |
| <b>COUPLING THE CONTAINERS</b>          | <b>2-7</b>  |
| <b>LIFTING SINGLE CONTAINERS</b>        | <b>2-11</b> |
| <b>LIFTING COUPLED CONTAINERS</b>       | <b>2-13</b> |
| <b>OPERATORS MAINTENANCE</b>            | <b>3-1</b>  |
| <b>OPERATOR TROUBLESHOOTING</b>         | <b>3-2</b>  |
| <b>UNIT MAINTENANCE</b>                 | <b>4-1</b>  |
| <b>UNIT TROUBLESHOOTING</b>             | <b>4-4</b>  |
| <b>DIRECT SUPPORT MAINTENANCE</b>       | <b>5-1</b>  |
| <b>DIRECT SUPPORT TROUBLESHOOTING</b>   | <b>5-4</b>  |

**HEADQUARTERS, DEPARTMENT OF THE ARMY**

**30 DECEMBER 1996**

## **WARNING SUMMARY**

### **WARNING**

To prevent serious injuries to crews and individuals, personnel located on the ground must remain eight to ten feet away from containers during lifting procedures. Always stand clear of forklift trucks when in use. Use extreme caution when moving containers to avoid injury.

### **WARNING**

Do not use decontamination spray on personnel. It may cause personal injury.

### **WARNING**

Some cleaning compounds may have hazardous fumes or skin irritants. Failure to observe any warning may cause personal injury or death. Follow all recommended procedures when using any cleaning compound.

### **WARNING**

Any device used to lift a single container must be rated to safely lift 10,000 pounds (4,536 kg). Any device used to lift coupled containers must be rated to safely lift 30,000 pounds (13,608 kg). Using improperly rated equipment could expose personnel to serious injury.

### **WARNING**

Welding over or around CARC painted surfaces will create dangerous gases which are hazardous to the operator's health. Operators must use proper OSHA approved respirators and equipment while repairs are made. Prior to welding on this equipment, refer to MIL-C-53072 - Chemical Agent Resistant Coating (CARC) System Application Procedures and Quality Control Inspection.

Refer to FM 21-11 for first aid instructions.

OPERATOR'S, UNIT, AND DIRECT SUPPORT  
MAINTENANCE MANUAL INCLUDING REPAIR PARTS AND  
SPECIAL TOOLS LIST (RPSTL)

FOR

TRICON CONTAINER

MODEL ESETC-01  
NSN 8145-01-389-9184

REPORTING ERRORS AND RECOMMENDING IMPROVEMENTS

You can help improve this manual. If you find any mistakes or if you know of a way to improve the procedures, please let us know. Mail your letter, DA Form 2028 (Recommended Changes to Publications and Blank Forms), or DA Form 2028-2 located in the back of this manual directly to: Commander, U. S. Army Aviation Troop Command, **ATTN: AMSAT-I-MP**, 4300 Goodfellow Blvd., St. Louis, MO 63120-1798. You may also submit your recommended changes by E-mail directly to <mpmt%avma28@st-louis-emh7.army.mil>. A reply will be furnished directly to you. Instructions for sending an electronic 2028 may be found at the back of this manual immediately preceding the hard copy 2028.

**DISTRIBUTION STATEMENT A: Approved for public release; distribution is unlimited.**

TABLE OF CONTENTS

|   | <u>Page</u> |
|---|-------------|
| HOW TO USE THIS MANUAL.....   | ii          |
| <b>CHAPTER 1 INTRODUCTION .....</b>                                       | <b>1-1</b>  |
| Section I General Information.....  | 1-1         |
| Section II <b>Equipment Description .....</b>                             | <b>1-3</b>  |
| Section III <b>Principles of Operation .....</b>                          | <b>1-5</b>  |
| <b>CHAPTER 2 OPERATING INSTRUCTIONS .....</b>                             | <b>2-1</b>  |
| Section I Description and Use of Operator's Controls and Indicators ..... | 2-2         |
| Section II Preventive Maintenance Checks and Services (PMCS).....         | 2-3         |
| Section III <b>Operation Under Usual Conditions.....</b>                  | <b>2-5</b>  |
| Section IV Operation Under Unusual Conditions .....                       | 2-14        |
| <b>CHAPTER 3 OPERATOR'S MAINTENANCE INSTRUCTIONS .....</b>                | <b>3-1</b>  |
| Section I Lubrication Instructions .....                                  | 3-2         |
| Section II <b>Troubleshooting.....</b>                                    | <b>3-2</b>  |
| Section III Maintenance.....  | 3-5         |

TABLE OF CONTENTS - CONTINUED

|                  | <u>Page</u>  |
|------------------|--|
| <b>CHAPTER 4</b> | <b>UNIT MAINTENANCE INSTRUCTIONS..... 4-1</b>              |
| Section I        | Lubrication..... 4-2                                       |
| Section II       | Service Upon Receipt..... 4-2                              |
| Section III      | Preventive Maintenance Checks and Services (PMCS)..... 4-2 |
| Section IV       | <b>Troubleshooting..... 4-4</b>                            |
| Section V        | Maintenance..... 4-4                                       |
| Section VI       | Preparation for Storage or Shipment ..... 4-8              |
| <b>CHAPTER 5</b> | <b>DIRECT SUPPORT MAINTENANCE INSTRUCTIONS ..... 5-1</b>   |
| Section I        | Lubrication..... 5-2                                       |
| Section II       | Service Upon Receipt..... 5-2                              |
| Section III      | Preventive Maintenance Checks and Services (PMCS)..... 5-2 |
| Section IV       | <b>Troubleshooting..... 5-4</b>                            |
| Section V        | Maintenance..... 5-7                                       |
| Section VI       | Preparation for Storage or Shipment ..... 5-14             |
| APPENDIX A       | REFERENCES ..... A-1                                       |
| APPENDIX B       | MAINTENANCE ALLOCATION CHART (MAC)..... B-1                |
| APPENDIX C       | REPAIR PARTS AND SPECIAL TOOLS LIST..... C-1               |
| APPENDIX D       | COMPONENTS OF END ITEM AND BASIC ISSUE ITEMS LIST..... D-1 |
| APPENDIX E       | ADDITIONAL AUTHORIZATION LIST..... E-1                     |
| APPENDIX F       | EXPENDABLE AND DURABLE ITEMS LIST..... F-1                 |
| APPENDIX G       | TORQUE LIMITS ..... G-1                                    |
| APPENDIX H       | MANDATORY REPLACEMENT PARTS..... H-1                       |
| APPENDIX I       | ILLUSTRATED LIST OF MANUFACTURED ITEMS..... I-1            |
| GLOSSARY         | .....GLOSSARY-1  |
| INDEX            | .....INDEX-1   |

**HOW TO USE THIS MANUAL**

The index along the right edge of the front cover provides quick reference to the major areas of concern. The tabs on the cover are aligned with corresponding tabs on the pages containing that information. Listings in the table of contents that are surrounded by a box correspond to listings on the front cover.

The manual is separated into distinct chapters that address a given topic or provide information useful to a certain maintenance level. Appendices contain further reference data.

Troubleshooting is presented in a logic-tree format in which a YES or NO answer provides you with the next action to perform. Appropriate maintenance procedures are referenced in the troubleshooting trees.

Maintenance procedures are presented in a step-by-step fashion. It is important to familiarize yourself with the entire maintenance procedure before beginning any task.

## CHAPTER 1

### INTRODUCTION

#### SECTION I. GENERAL INFORMATION

##### **1.1 SCOPE.**

1.1.1 Type of Manual: Operator's, unit, and direct support maintenance.

1.1.2 Model Number and Equipment: Model ESETC-01, NSN 8145-01-389-9184 Tricon Container.

1.1.3 Purpose of Equipment: The Tricon Container (Figure 1-1) is used to store and ship cargo. Adjustable shelves and provisions for tiedown allow different sized cargo to be loaded.

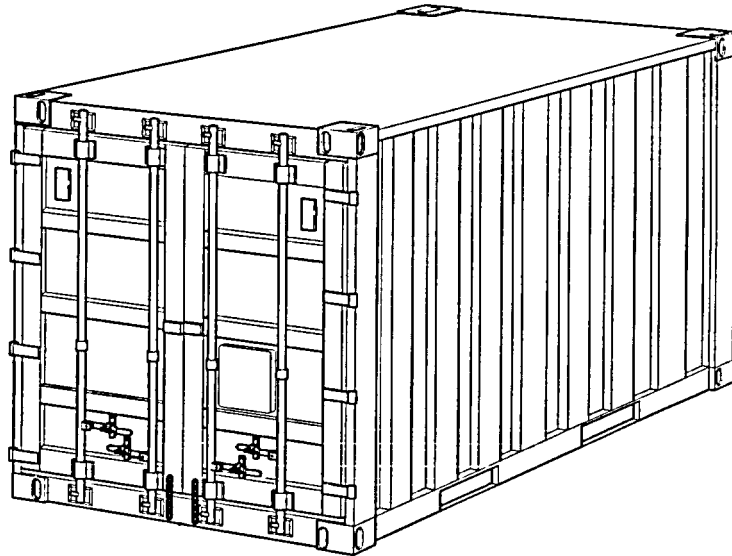

*Figure 1-1. Tricon Container.*

**1.2 MAINTENANCE FORMS AND PROCEDURES.**

Department of the Army forms and procedures used for equipment maintenance will be those prescribed by DA PAM 738-750 as contained in the Maintenance Management Update.

**1.3 CORROSION PREVENTION AND CONTROL.**

1.3.1 Corrosion Prevention and Control (CPC) of Army materiel is a continuing concern. Report all corrosion problems with this item to help correct defects and assist in making improvements to prevent future errors.

1.3.2 While corrosion is usually associated with rusting of metals, it can also include deterioration of other materials, such as rubber and plastic. Unusual cracking, softening, swelling or breaking of these materials may be a corrosion problem. If a corrosion problem is identified, report it using Standard Form 368, Product Quality Deficiency Report. Use of key words such as "corrosion," "rust," "deterioration," or "cracking" will ensure that the information is identified as a CPC problem. Submit the form to the address specified in DA PAM 738-750.

**1.4 DESTRUCTION OF ARMY MATERIEL TO PREVENT ENEMY USE.**

Procedures for destruction of materiel to prevent enemy use may be found in TM 750-244-3.

**1.5 PREPARATION FOR STORAGE OF SHIPMENT.**

No special procedures are required for storage or shipment. Refer to Operation Under Usual Conditions (Chapter 2, Section III).

**1.6 QUALITY ASSURANCE.**

No QA information is included in this TM. When reference is made to other TMs, be sure to follow any QA data contained in them.

**1.7 REPORTING EQUIPMENT IMPROVEMENT RECOMMENDATION (EIR).**

If your Tricon Container needs improvement, let us know. Send us an EIR. You, the user, are the only one who can tell us what you don't like about your equipment. Let us know why you don't like the design or performance. Put it on an SF 368 (Product Quality Deficiency Report). Mail it to us at: Commander, U.S. Army Aviation and Troop Command, ATTN: AMSAT-I-MDO, 4300 Goodfellow Blvd., St. Louis, MO 63120-1798.

**1.8 WARRANTY INFORMATION.**

No warranty is provided with the container.

**1.9 NOMENCLATURE CROSS-REFERENCE LIST.**

Common Name

Official Nomenclature

Tricon Container  
or container

Container, Shipping and Storage - Triple (Tricon)  
with connectors (with and without shelves)

**1.10 LIST OF ABBREVIATIONS/ACRONYMS.**

|      |  |
|------|--|
| CARC | Chemical Agent Resistant Coating             |
| in   | inches                                       |
| kg   | kilograms                                    |
| lb   | pounds                                       |
| mm   | millimeter                                   |
| MTOE | Modified Table of Organization and Equipment |
| NSN  | National Stock Number                        |
| PMCS | Preventive Maintenance Checks and Services   |
| TM   | Technical Manual                             |

**1.11 GLOSSARY.**

A complete glossary is found in the back of this manual after the Appendices.

**1.12 REPAIR PARTS; TOOLS; SPECIAL TOOLS; TMDE AND SUPPORT EQUIPMENT.**1.12.1 Common Tools and Equipment.

For authorized common tools and equipment, refer to the Modified Table of Organization and Equipment (MTOE), CTA 50-970, or CTA 8-100, as applicable to your unit.

1.12.2 Specials Tools, TMDE, and Support Equipment.

No special tools, Test, Measurement and Diagnostic Equipment (TMDE), or support equipment are required.

1.12.3 Repair Parts.

Repair parts are listed and illustrated in Appendix C of this manual.

**SECTION II. EQUIPMENT DESCRIPTION****1.13 EQUIPMENT CHARACTERISTICS, CAPABILITIES, AND FEATURES.**

1.13.1 The Tricon Container is a steel container with two doors on one face. The container is painted with a Chemical Agent Resistant Coating (CARC). Containers with serial numbers less than TC0100263 have twelve shelf support beams that span the width of the container and connect to vertical shelf supports welded to the container sides. The support beams are grouped in sets of three to form a horizontal support for shelves. One support beam spans the middle of the container and the other two are located at either end. Two shelves are placed on top of each set of support beams to form a secure surface for loading material. Containers with serial numbers TC0100263 or greater do not have shelves or shelf support beams.

1.13.2 Each door has two lockrod assemblies that secure the door in the closed position. The lockrod assemblies are each moved into or out of their locked position by a handle. Ventilators are located at an upper corner of each door and at the upper corners of the rear of the container. Containers with serial numbers up to TC0100323 have closable vents. Containers with serial number TC0100324 or greater use non-closable vents.

1.13.3 Connecting link assemblies are included with each container. These link assemblies are used to connect three containers together. The corners of the containers have oblong cutouts. The link assemblies are partially inserted into these cutouts and operated in a manner that locks the containers together. When not in use the connecting link assemblies are stored in an open box on the inside of the right-hand door.

**1.14 LOCATION AND DESCRIPTION OF MAJOR COMPONENTS.**

Review Figure 1-2 below for the location and description of major components.

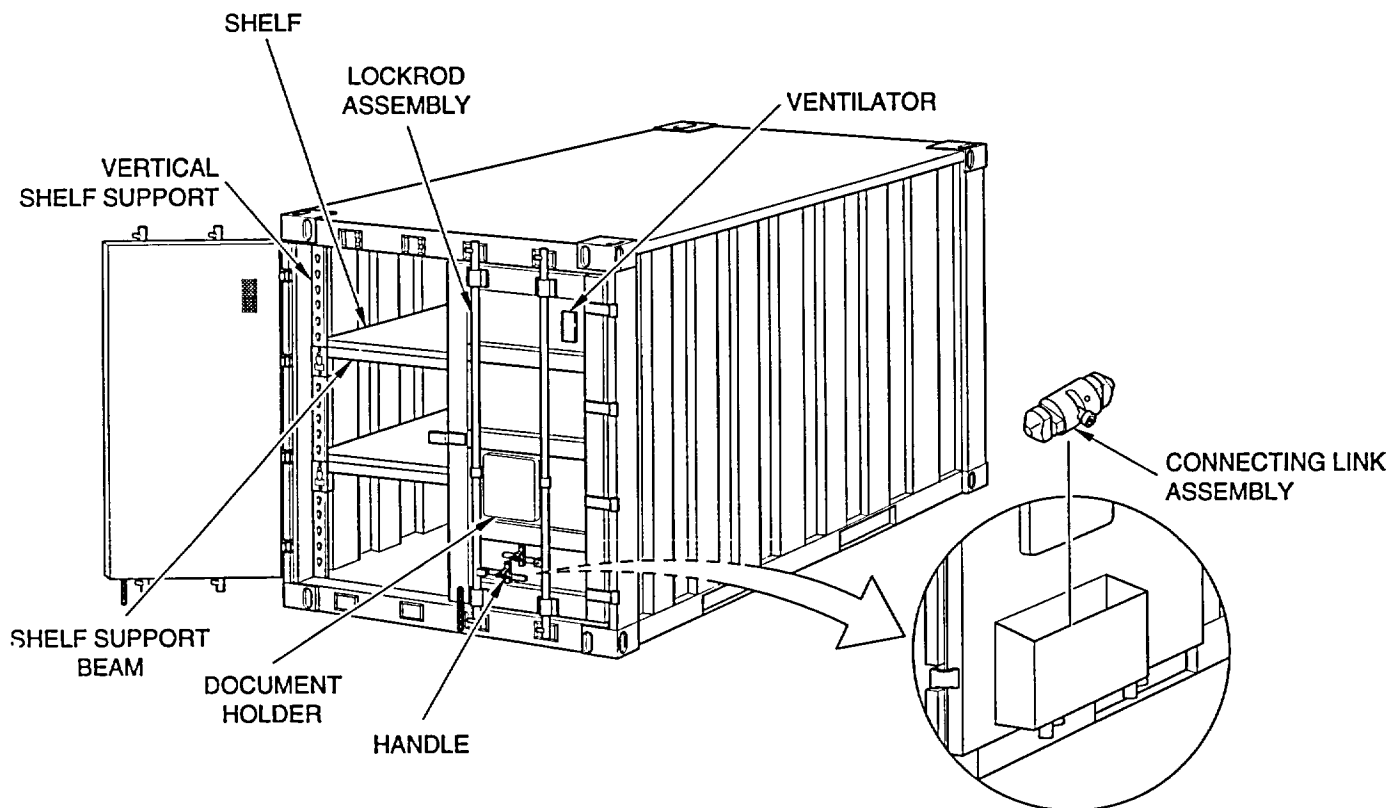

Figure 1-2. Major Components.

**1.15 EQUIPMENT DATA.**

The table below lists all applicable container data.

Table 1-2. Weights and Dimensions

|   |  |
|---|--|
| <b>EXTERNAL</b>                                 |  |
| Length.....                                     | 8'-0" (2438 mm)                              |
| Width.....                                      | 6'-5 1/2" (1968 mm)                          |
| Height.....                                     | 8'-0" (2438 mm)                              |
| <b>INTERNAL</b>                                 |  |
| Length.....                                     | 7'-6 7/16" (2297 mm)                         |
| Width.....                                      | 6'-2" (1881 mm)                              |
| Height.....                                     | 7'-5 13/16" (2284 mm)                        |
| Door Opening Width.....                         | 6'-1 5/8" (1870 mm)                          |
| Door Opening Height.....                        | 7'-1 13/16" (2164 mm)                        |
| Max. Gross Weight.....                          | 10,000 lb (4536 kg)                          |
| Tare Weight (without shelves and brackets)..... | 2700 lb (1225 kg)                            |
| Tar Weight (with shelves and brackets).....     | 3100 lb (1406 kg)                            |
| Payload Weight.....                             | 6900 lb (3130 kg)                            |
| Internal Volume.....                            | 346.1 ft <sup>3</sup> (9.86 m <sup>3</sup> ) |



**SECTION III. PRINCIPLES OF OPERATION****1.16 GENERAL.**

The Tricon Container is a storage unit. Some containers have adjustable shelves. Open container doors by lifting handles up and then pulling them towards you. This disengages the lockrod assembly and frees the doors. If applicable, change shelf positions by sliding shelf support beams up and down the vertical shelf supports. Three containers may be attached using connecting link assemblies that connect the corner fittings on the containers. (See Figure 1-2.)

**CHAPTER 2**  
**OPERATING INSTRUCTIONS**

|             |  | Page |
|-------------|--|------|
| Section I   | Description and use of operator's controls and indicators..... | 2-2  |
|             | 2.1 Overview.....  | 2-2  |
| Section II  | Preventive maintenance checks and services (PMCS).....         | 2-3  |
|             | 2.2 General.....   | 2-3  |
|             | 2.3 PMCS procedures.....                                       | 2-3  |
|             | 2.4 PMCS table.....  | 2-4  |
| Section III | Operation under usual conditions.....                          | 2-5  |
|             | 2.5 Assembly and preparation for use.....                      | 2-5  |
|             | 2.6 Initial checks.....  | 2-5  |
|             | 2.7 Opening the doors.....                                     | 2-5  |
|             | 2.8 Adjusting the shelves.....                                 | 2-5  |
|             | 2.9 Loading the container.....                                 | 2-6  |
|             | 2.10 Closing the container.....                                | 2-7  |
|             | 2.11 Coupling the containers.....                              | 2-7  |
|             | 2.12 Uncoupling the containers.....                            | 2-9  |
|             | 2.13 Lifting single containers.....                            | 2-11 |
|             | 2.14 Lifting coupled containers.....                           | 2-13 |
| Section IV  | Operation under unusual conditions.....                        | 2-14 |
|             | 2.15 Overview.....   | 2-14 |
|             | 2.16 Decontamination procedures.....                           | 2-14 |

**SECTION I. DESCRIPTION AND USE OF OPERATOR'S CONTROLS AND INDICATORS**

**2.1 OVERVIEW.**

1. Securing Latch. Keeps the handles in the closed position.
2. Handles. When securing latch is released, the handles can be pivoted up then out. When both handles on both doors are pivoted out, the doors can be opened.
3. Door Chains. Used to keep the open door from swinging closed. When door is open, secure the free end of the door chain to the tie-back hook on the side of the container.
4. Ventilator. Slide open to allow ventilation. Slide closed to stop ventilation. This applies only to containers with serial numbers up to TC0100323. Containers with serial numbers TC0100324 or greater use non-closable vents.
5. Connecting Link Assembly. Used at the corners on each side of the container to connect two containers together.
6. Handle. Used to adjust the connector to the desired position when two containers are being connected.

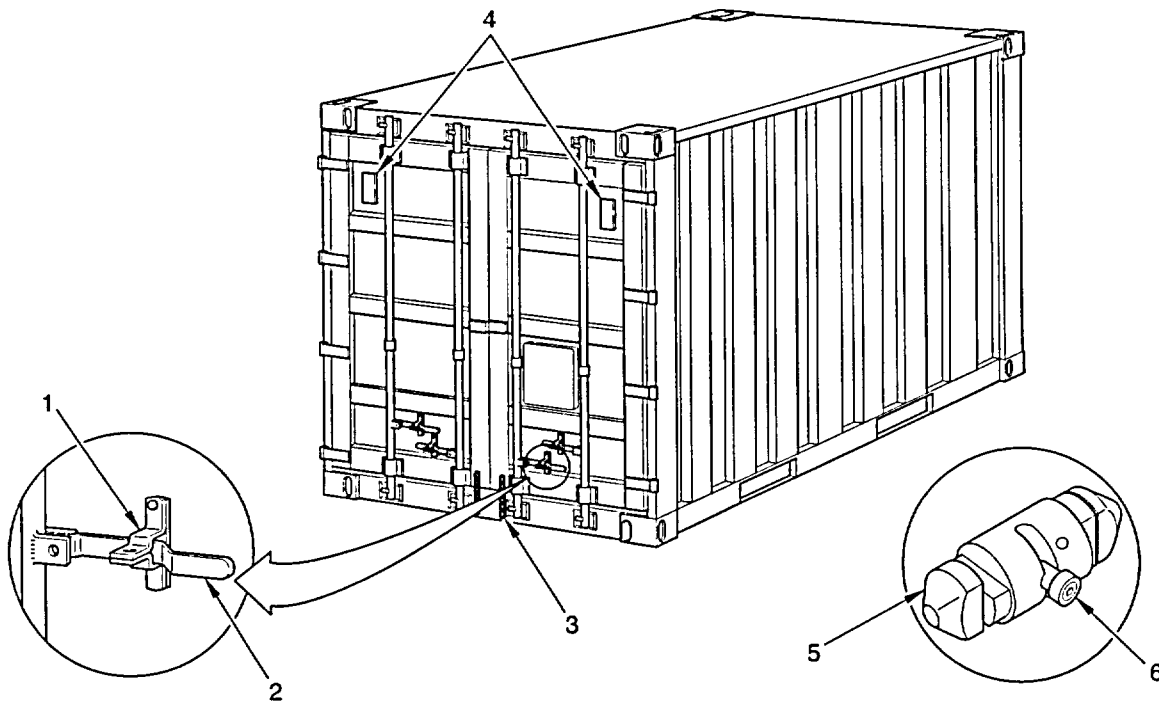

## SECTION II. PREVENTIVE MAINTENANCE CHECKS AND SERVICES (PMCS)

### 2.2 GENERAL.

Preventive Maintenance Checks and Services (PMCS) means systematic caring, inspecting and servicing of equipment to keep it in good condition and to prevent breakdowns. As Tricon container operator, your mission is to:

- a. Be sure to perform your PMCS each time you operate the container. Always do your PMCS in the same order so it gets to be a habit. Once you have had some practice, you will quickly spot anything wrong.
- b. Do your BEFORE (B) PMCS just before you operate the container. Pay attention to WARNINGS, CAUTIONS and NOTES.
- c. Use DA Form 2404 (Equipment Inspection and Maintenance Worksheet) to record any faults that you discover before, during, or after operation, unless you can fix them. You DO NOT need to record faults that you fix.
- d. Perform any other services when required by organizational maintenance.

### 2.3 PMCS PROCEDURES.

2.3.1 Your Preventive Maintenance Checks and Services, Table 2-1, lists inspections and care required to keep the container in good operating condition. It is set up so you can make your BEFORE (B) OPERATION checks as you walk around the container.

2.3.2 The Interval column of table 2-1 tells you when to do a certain check or service.

2.3.3 The Procedure column of table 2-1 tells you how to do required checks and services. Carefully follow these instructions.

#### NOTE

**Terms "ready/available" and "mission capable" refer to same status: Equipment is on hand and ready to perform its combat missions. (See DA PAM 738-750.)**

2.3.4 The Equipment Is Not Ready/Available column in table 2-1 tells you when your container is not mission capable and why the container cannot be used.

2.3.5 If the container does not perform as required, refer to Chapter 3, Section II, Troubleshooting.

2.3.6 If anything looks wrong and you cannot fix it, write it on your DA Form 2404 and immediately report it to your supervisor.

**2.4 PMCS TABLE**

Table 2-1. Preventive Maintenance Checks and Services For Tricon Container Location

| Item Number | Interval | Location                          |  | Procedure   | Not Fully Mission Capable If:  |
|-------------|----------|-----------------------------------|--|---|--|
|             |          | Item to Check/ Service            |  |   |  |
| 1           | Before   | Door handles and related hardware |  | Inspect for any broken welds or defective parts. Operate handles.                               | Handles or related hardware are broken or if handles will not open door. |
| 2           | Before   | Document holder                   |  | Inspect for any large dents that may prevent the holder from being completely opened or closed. | Document holder cannot be completely opened or closed.                   |
| 3           | Before   | Shelf assembly                    |  | Inspect for cracked or broken welds.  | Any welds are cracked or broken.   |
| 4           | Before   | Support beams                     |  | Inspect support beams for complete welds and working clips.                                     | Any welds or clips are defective.  |
| 5           | Before   | Door seals                        |  | Inspect for tears.  | Door seals are torn.   |
| 6           | Before   | Vents                             |  | Inspect for broken vents.   | Vents are broken.  |
| 7           | Before   | Connecting link assembly          |  | Check that handle can be pulled out and shifted 90 degrees.                                     | If handle is jammed or cannot be shifted.                                |

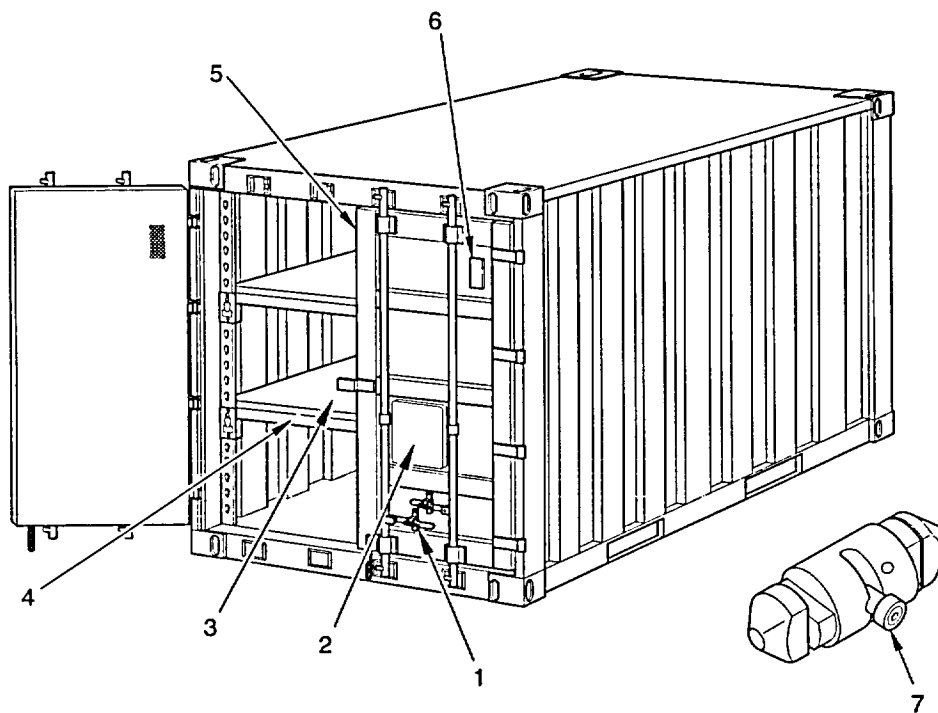

**SECTION III. OPERATION UNDER USUAL CONDITIONS**

**2.5 ASSEMBLY AND PREPARATION FOR USE.**

No special instructions are needed before use. Refer to the PMCS table (table 2-1) for usual instructions.

**2.6 INITIAL CHECKS.**

No special checks are required before use. Refer to PMCS table (table 2-1) for usual instructions.

**2.7 OPENING THE DOORS.**

- a. Rotate each securing latch mechanism (1) up to release handle (2).
- b. Move handle (2) up out of each retainer. Then pull handle towards you to release the lockrod assembly. Do this on all four handles to open both doors.

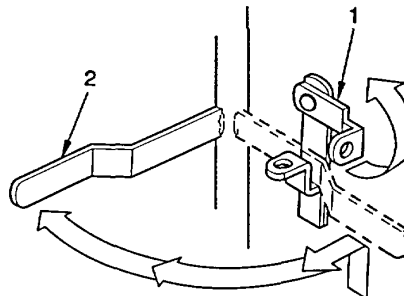

**2.8 ADJUSTING THE SHELVES.**

- a. Remove enough shelves (1) to allow access to the shelf support beams that need to be moved. Simply lift shelves slightly and pull out.

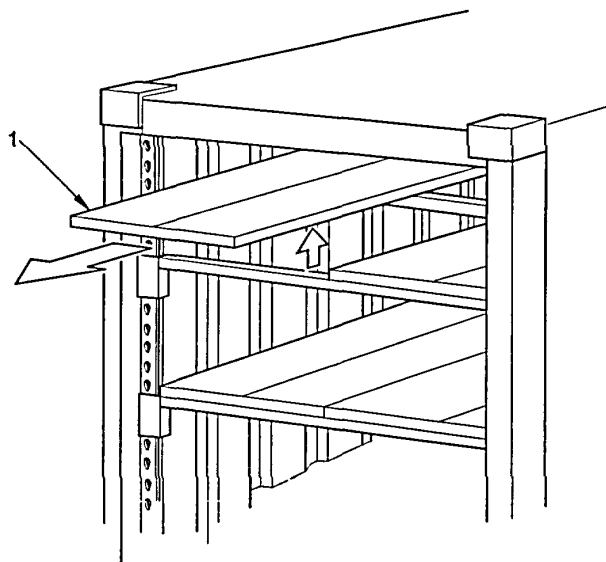

- b. Pull out the spring clip (1) on the left-hand shelf support beam (2). With clip pulled out, slide the beam up until the rivets (4) can be disengaged from the tear-drop cutouts in the vertical shelf support (3).
- c. Repeat the above step on the right-hand shelf support beam.
- d. Move both support beams up or down to the desired position.
- e. Secure the left-hand support beam by pulling out the spring clip (1) and inserting the rivets (4) into the tear-drop cutouts on the vertical shelf support (3). Lower the support beam (2) until rivets (4) completely engage the vertical shelf support (3). Release the spring clip (1) to secure the support in place.
- f. Repeat Step e on the right-hand support beam.
- g. Repeat Steps e and f until all three support beam assemblies have been adjusted to the same height.
- h. Install shelves on top of support beams.

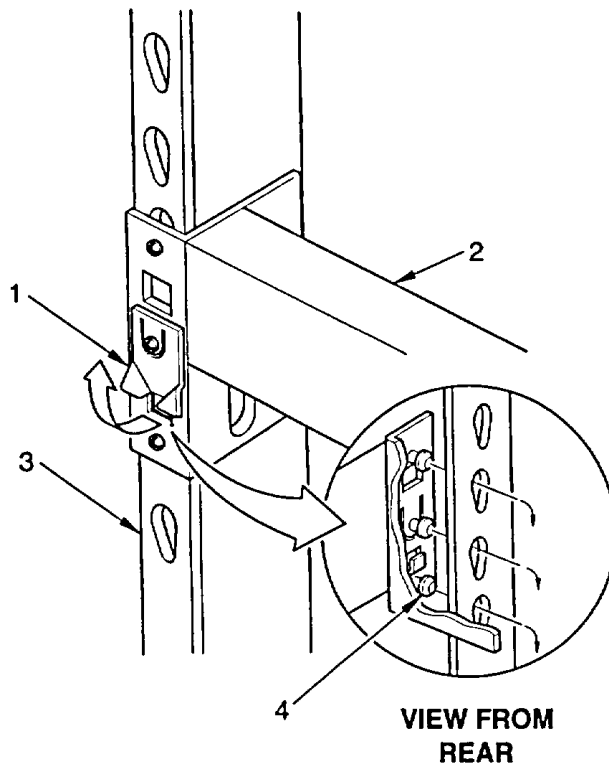

**2.9 LOADING THE CONTAINER.**

After the shelf support beams have been adjusted to desired positions (refer to Paragraph 2.8) the container may be loaded.

- a. For easier loading, it is usually desirable to place heavier items on the floor or lower shelves. Distribute the load as evenly as possible.
- b. To prevent excessive movement, fill each shelf as much as possible.
- c. Tie-downs are provided in all corners and along the tops and bottoms of the side and front walls. Cargo may be secured to these tie-downs using rope or webbing.

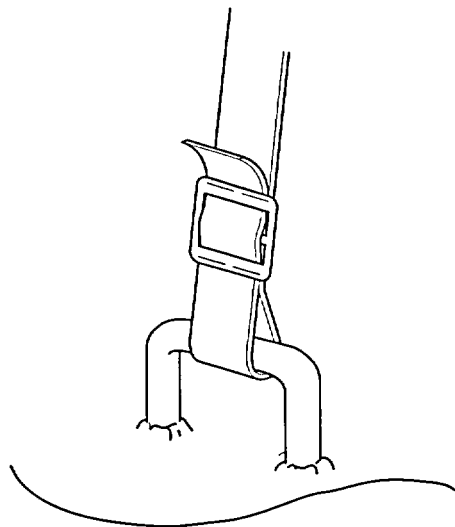

**2.10 CLOSING THE CONTAINER.**

After the cargo has been properly loaded and secured the doors may be closed.

- a. Swing the left-hand door closed first. Then swing the right-hand door to the closed position.
- b. Rotate each handle (1) toward the appropriate door and lower the handle flush against the door and resting in the base of the securing latch.
- c. Rotate securing latch (2) down to keep handle (1) in position.

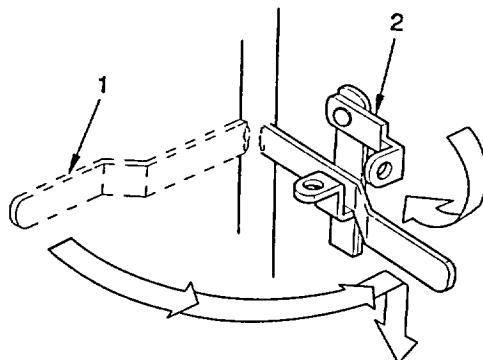
**2.11 COUPLING THE CONTAINERS.**

Three containers may be coupled together to form a single unit. Eight connecting link assemblies are required to couple three containers. Obtain the link assemblies from the box located inside the right-hand door of each container. To join the containers, use the following procedure.

- a. Make sure the locking handle (1) is in the locked position. The locked position is when the handle (1) is in the deep, center hole on the connecting link assembly. Locate the end that has the free-moving alignment collar (2). This is the end that will be inserted first.
- b. Orient the connecting link assembly so the locking handle (1) is pointing toward the front or rear of the container. Position the free-moving alignment collar (2) so it is aligned with the cone-shaped portion of the connecting link assembly.
- c. Insert the link assembly into the corner opening on the container side.

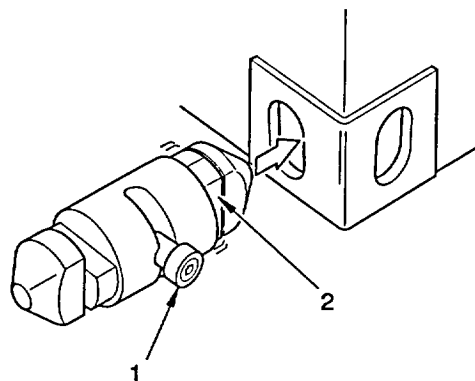



- d. Rotate the link assembly so the locking handle (1) is pointing up.

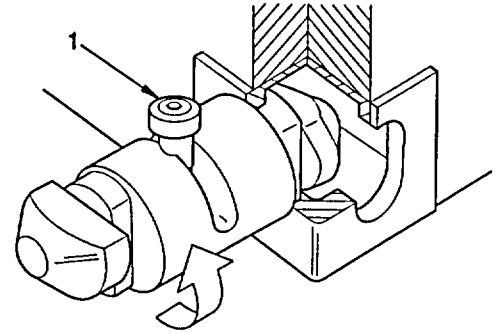

- e. Hold the main body portion (1) of the connecting link assembly in place and pull the locking handle (2) up and move the handle to the horizontal position. This rotates the outer cone-shaped end (3) to the proper orientation.

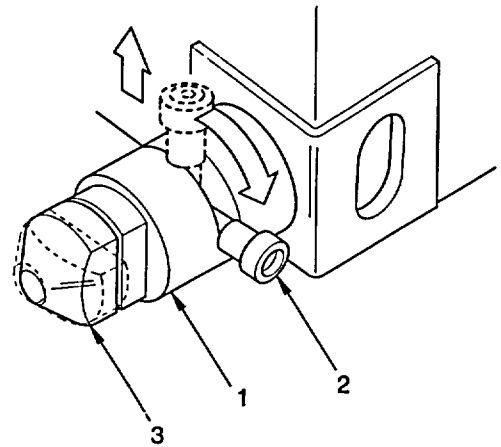

- f. Repeat Steps a through e at all four corners.

- g. Slide the mating container (1) onto the four connecting link assemblies (2).

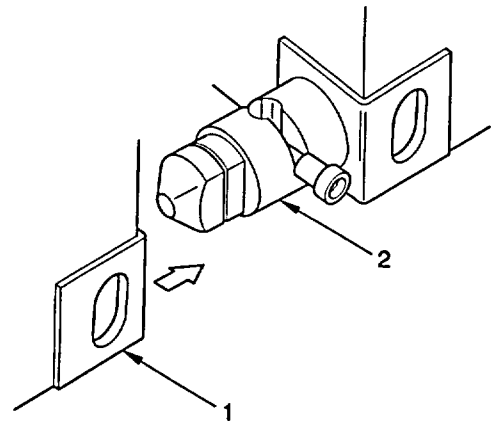

- h. Move the locking handle (1) back to the vertical position. Make sure the handle slips into the notch. Perform this step at all four corners. This locks the containers together.

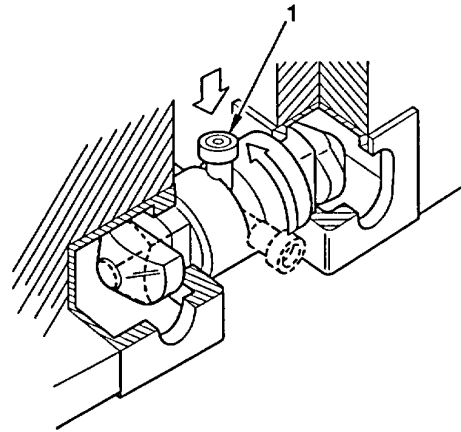

**2.12 UNCOUPLING THE CONTAINERS.**

- a. On all four connecting link assemblies (1), lift the locking handle (2) and move the handle to the unlocked, horizontal position.

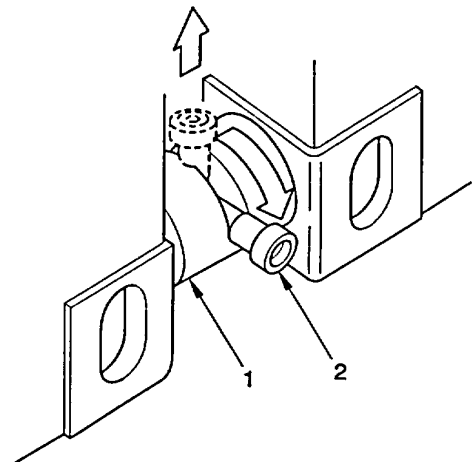

- b. Slide the containers apart.

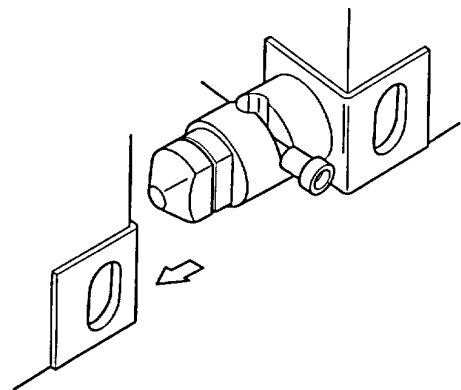

- c. Return the locking handle (1) to the upright, locked position. Make sure the handle is recessed in the central hole.

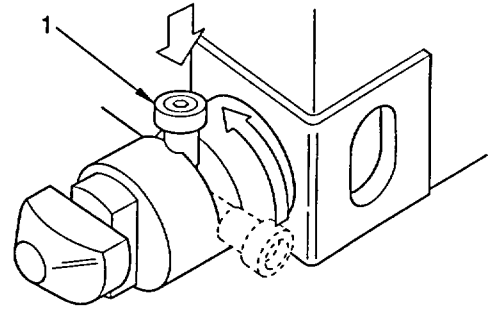

- d. Rotate the connecting link assembly 90 degrees to align the inside end cone with corner opening. Remove the link assembly from the opening.

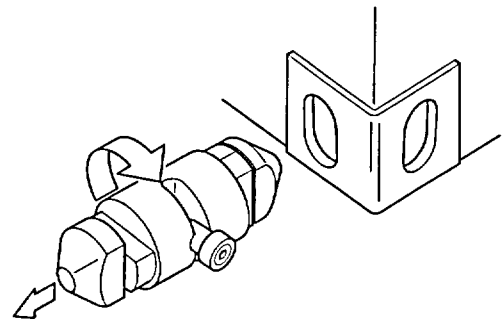

- e. Store link assemblies in the tool box on the inside of the right-hand door. Each container should have three link assemblies.

**2.13 LIFTING SINGLE CONTAINERS.**

**WARNING**

- To prevent serious injuries to crews and individuals, personnel located on the ground must remain eight to ten feet away from containers during lifting procedures. Always stand clear of forklift trucks when in use. Use extreme caution when moving containers to avoid injury.
- Any device used to lift a single container must be rated to safely lift 10,000 pounds (4,536 kg). Using improperly rated equipment could expose personnel to serious injury.

2.13.1 Lifting from Top Corner Fitting.

- a. Four individual slings may be attached to the four top corners and lifted straight up. Attach the slings to the corners using a hook or other suitable method.

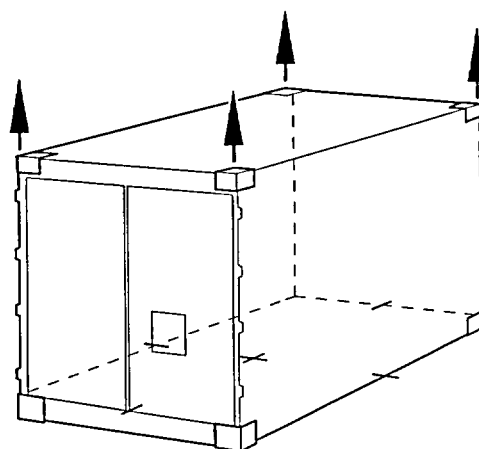

- b. Also, four slings from the corners can be attached to a single lifting sling. If this method is used, the four slings should be long enough to ensure that the angle between the roof and the sling is a minimum of 60 degrees.

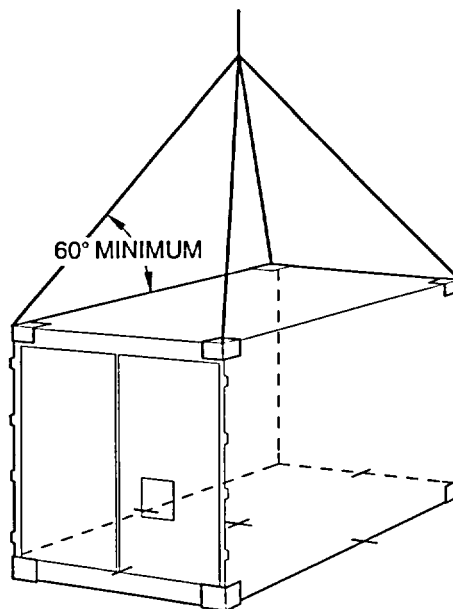

2.13.2 Lifting from Bottom Corners. When lifting from the bottom corners, a spreader bar should be used to keep the slings from rubbing on the container. The slings should be long enough to ensure that a minimum angle of 60 degrees exists between the floor and the slings.

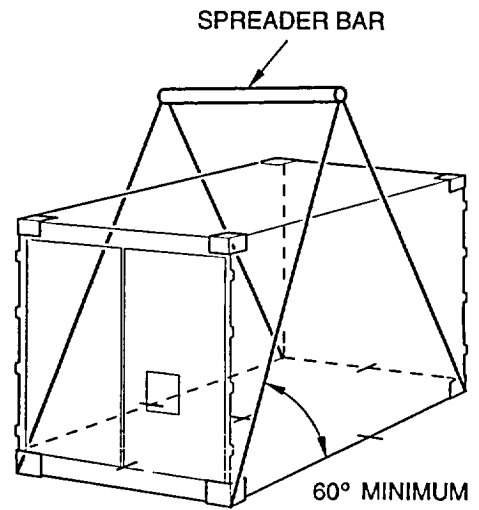

2.13.3 Lifting with Forklift. Single containers may be lifted by a forklift using either the slots on the container front or on either side.

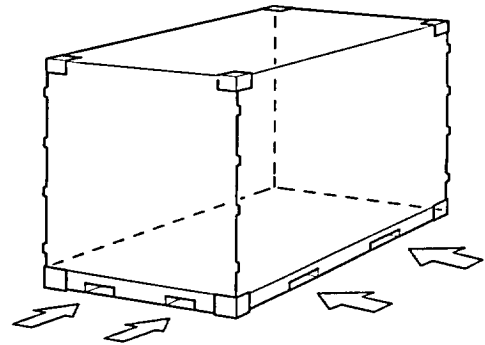

**2.14 LIFTING COUPLED CONTAINERS.****WARNING**

- To prevent serious injuries to crews and individuals, personnel located on the ground must remain eight to ten feet away from containers during lifting procedures. Always stand clear of forklift trucks when in use. Use extreme caution when moving containers to avoid injury.
- Any device used to lift coupled containers must be rated to safely lift 30,000 pounds (13,608 kg). Using improperly rated equipment could expose personnel to serious injury.

2.14.1 Lifting by Top Corner. Connect four slings to the outermost corner fittings. The lifting force must be vertical only. Use hooks or other suitable devices to attach the slings to the corner.

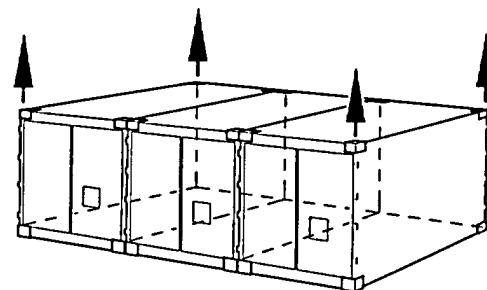

2.14.2 Lifting from Bottom Corners. When lifting from the bottom corners, a spreader bar should be used to keep the slings from rubbing on the container. The slings should be long enough to ensure that a minimum angle of 45 degrees exists between the floor and the slings.

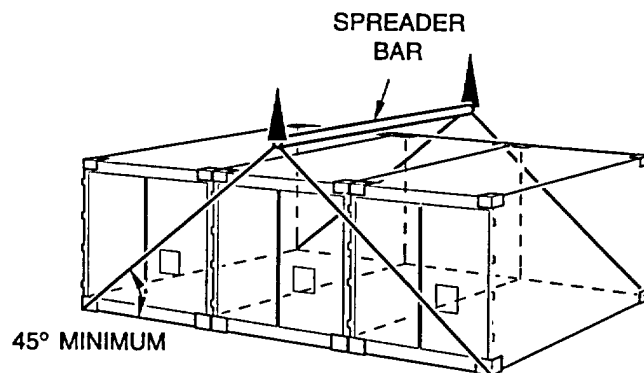

2.14.3 Lifting by Forklift. When using a forklift to lift coupled containers use only the forklift slots on the center container.

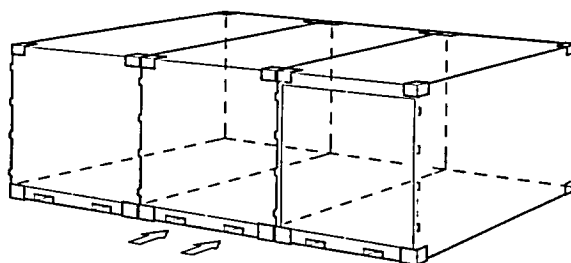

USE FORKLIFT SLOTS  
IN CENTER CONTAINER ONLY

## SECTION IV. OPERATION UNDER UNUSUAL CONDITIONS

### **2.15 OVERVIEW.**

Container operation under unusual conditions is the same as operation under usual conditions. Refer to Section III for usual operating instructions.

### **2.16 DECONTAMINATION PROCEDURES.**

#### 2.16.1 General.

Perform the emergency procedures below until field nuclear, biological, or chemical (NBC) decontamination facilities are available. Commander will supervise, assign new duties, and assist the supporting NBC unit.

#### 2.16.2 Emergency Procedures.

If NBC attack is known or suspected, mask at once and continue mission. Follow decontamination procedures below. Do not unmask until told to do so.

2.16.2.1 Nuclear Decontamination. Brush fallout from skin, clothing and equipment with available brushes, rags, and tree branches. Wash skin and have radiation check made as soon as tactical situation permits. (You can find instructions for the check in FM 3-5.)

2.16.2.2 Biological Contamination. Container crew has no method to detect or decontaminate biological agents. Remain masked and continue mission until told to unmask.

### **WARNING**

**Do not use decontamination spray on personnel. It may cause personal injury.**

2.16.2.3 Chemical Detection and Decontamination. Use M8 paper from M256 chemical agent detector kit or M9 paper to determine if liquid agent is present on container surface. If exposure to liquid agent is known or suspected, clean exposed skin, clothing, and personal gear, in this order, using M258A1 kit. Use the buddy system. Wash exposed skin and thoroughly decontaminate as soon as tactical situation permits. If M8 or M9 paper indicates that a liquid chemical agent is present on container surface, use the ABC-M11 decontamination apparatus for partial decontamination of container. Spray only surfaces that will be touched going into and coming out of container.

CHAPTER 3

OPERATOR'S MAINTENANCE INSTRUCTIONS

|  | Page |
|--|------|
| Section I                                    |      |
| Lubrication instructions.....                | 3-2  |
| 3.1 Lubrication.....                         | 3-2  |
| Section II                                   |      |
| Troubleshooting.....                         | 3-2  |
| 3.2 Introduction .....                       | 3-2  |
| 3.3 Cargo is damaged by weather .....        | 3-2  |
| 3.4 Cargo is damaged by movement.....        | 3-3  |
| 3.5 Doors do not close.....                  | 3-3  |
| 3.6 Doors do not open .....                  | 3-4  |
| 3.7 Documents are damaged .....              | 3-4  |
| 3.8 Containers cannot be coupled.....        | 3-4  |
| Section III                                  |      |
| Maintenance.....                             | 3-5  |
| 3.9 Shelf, replace.....                      | 3-5  |
| 3.10 Connecting link assembly, replace ..... | 3-5  |



**SECTION I. LUBRICATION INSTRUCTIONS**

**3.1 LUBRICATION.**

Lubrication is not required.

**SECTION II. TROUBLESHOOTING**

**Malfunction Index**

|                                   | Troubleshooting<br>Procedure<br>(Para) |
|-----------------------------------|--|
| Cargo is damaged by weather.....  | 3.3                                    |
| Cargo is damaged by movement..... | 3.4                                    |
| Doors do not close.....           | 3.5                                    |
| Doors do not open.....            | 3.6                                    |
| Documents are damaged.....        | 3.7                                    |
| Containers cannot be coupled..... | 3.8                                    |

**3.2 INTRODUCTION.**

The troubleshooting tables in Paragraphs 3.3 through 3.8 list the common malfunctions that may occur. Perform the procedures in the order that they appear in the tables.

**3.3 CARGO IS DAMAGED BY WEATHER.**

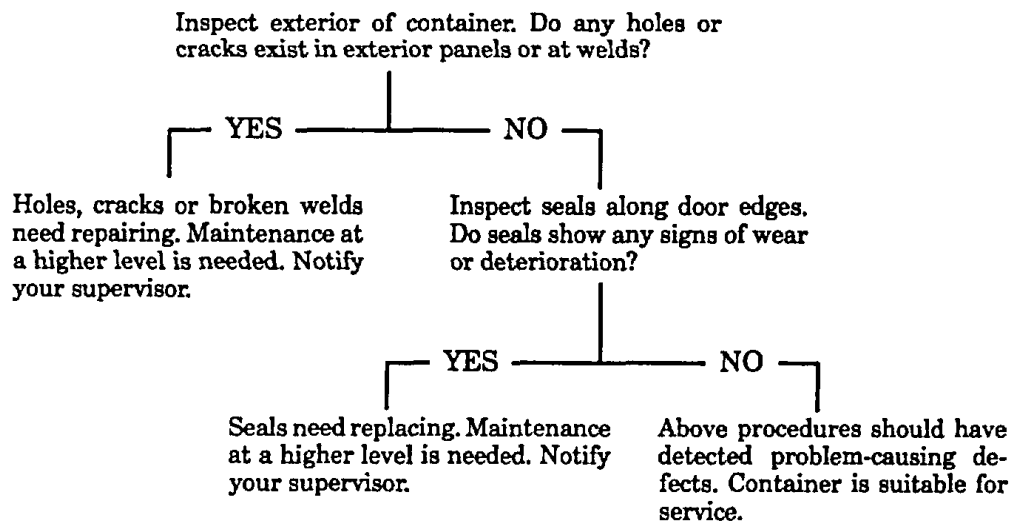

**3.4 CARGO IS DAMAGED BY MOVEMENT.**

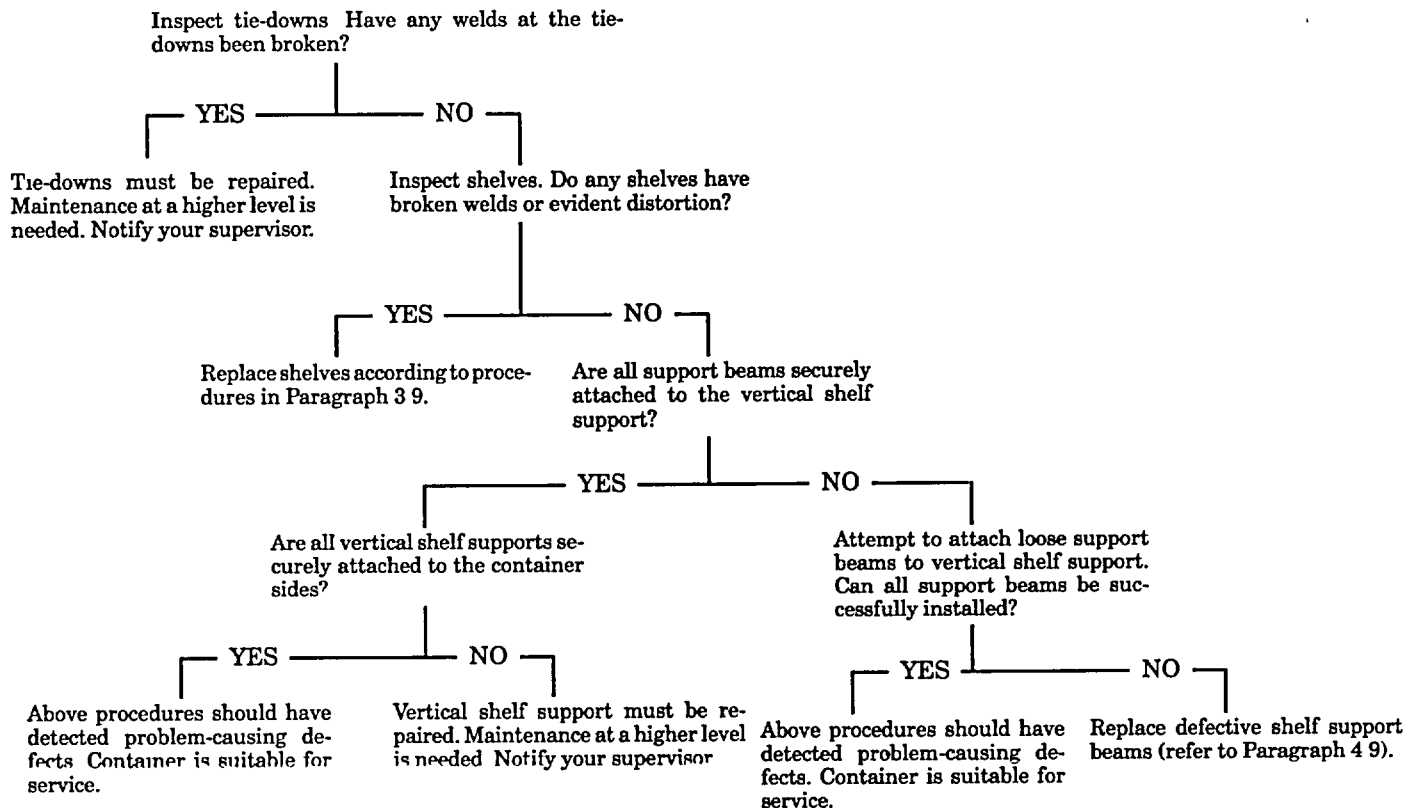

**3.5 DOORS DO NOT CLOSE.**

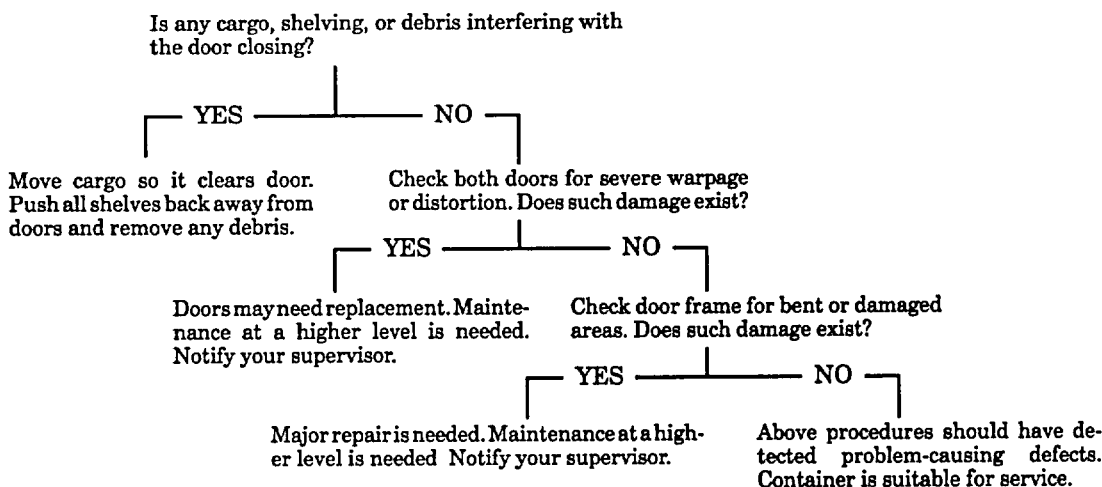

**3.6 DOORS DO NOT OPEN.**

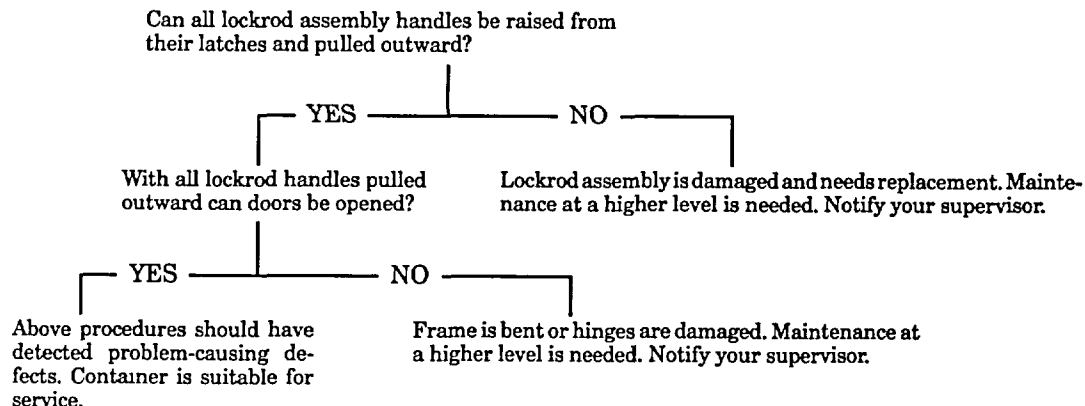

**3.7 DOCUMENTS ARE DAMAGED.**

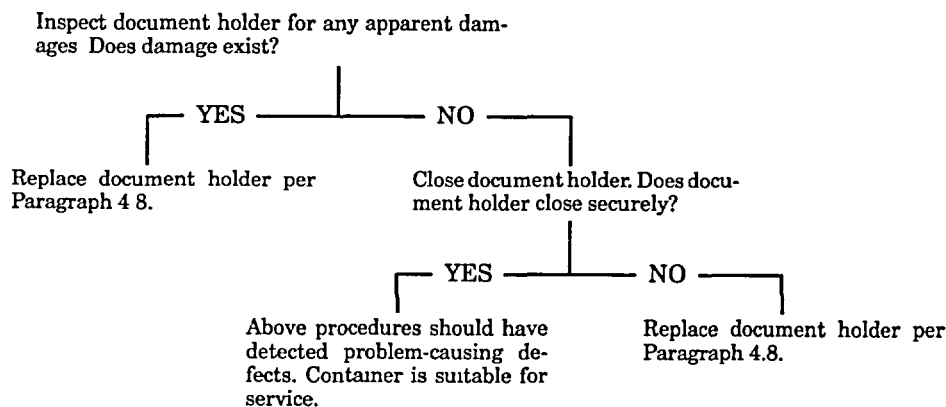

**3.8 CONTAINERS CANNOT BE COUPLED.**

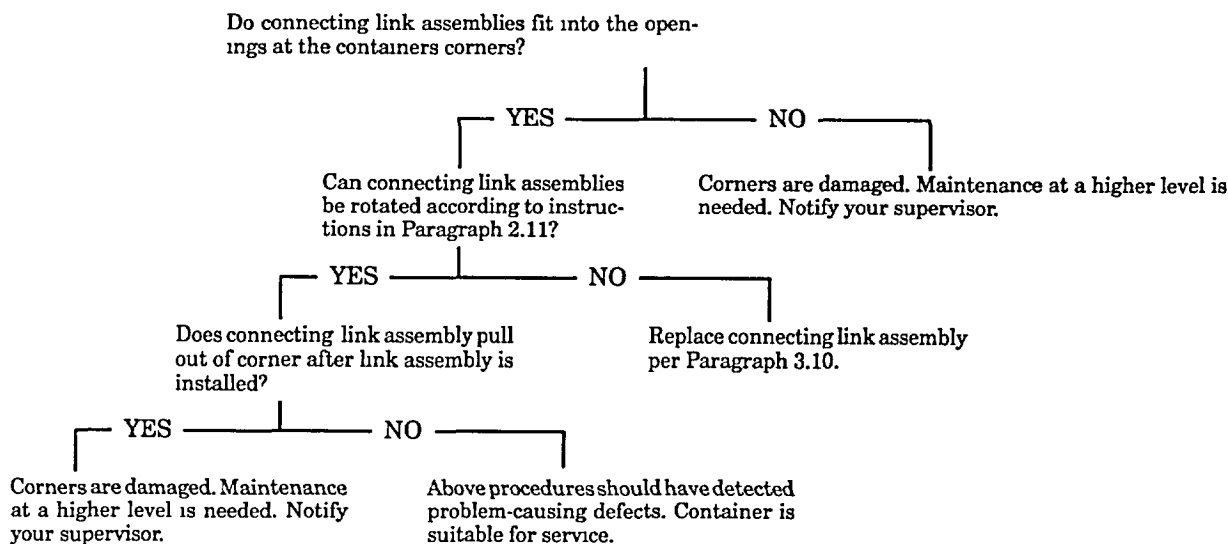

**SECTION III. MAINTENANCE**

**Maintenance Procedures**

|  |          |
|--|----------|
| Shelf, replace .....                           | Para 3.9 |
| Connecting link assembly, remove/install ..... | 3.10     |

**3.9 SHELF, REPLACE.**

This task covers: a. Removal                      b. Installation

**Initial Setup:**

|              |                            |
|--------------|----------------------------|
| <u>Tools</u> | <u>Equipment Condition</u> |
|--------------|----------------------------|

|      |                   |
|------|-------------------|
| None | Doors are opened. |
|------|-------------------|

Materials/Parts Required

None

a. Removal

Shelves have no attaching part. Simply slide the damaged shelf from its position.

b. Installation

Slide in the new shelf.

**3.10 CONNECTING LINK ASSEMBLY, REPLACE.**

This task covers: a. Removal                      b. Installation

**Initial Setup:**

|              |                            |
|--------------|----------------------------|
| <u>Tools</u> | <u>Equipment Condition</u> |
|--------------|----------------------------|

|      |                          |
|------|--------------------------|
| None | Right-hand door is open. |
|------|--------------------------|

Materials/Parts Required

None

a. Removal

Connecting link assemblies have no attaching hardware. Remove and discard the defective link assembly.

b. Installation

Place the new connecting link assembly in the box on the inside of the right-hand door.

CHAPTER 4

UNIT MAINTENANCE INSTRUCTIONS

|             | Page  |
|-------------|---|
| Section I   | Lubrication instructions..... 4-2                             |
|             | 4.1 Lubrication..... 4-2                                      |
| Section II  | Service upon receipt ..... 4-2                                |
|             | 4.2 General ..... 4-2   |
| Section III | Preventive maintenance checks and services (PMCS)..... 4-2    |
|             | 4.3 General ..... 4-2   |
|             | 4.4 PMCS procedures..... 4-3                                  |
|             | 4.5 PMCS table ..... 4-3                                      |
| Section IV  | Troubleshooting ..... 4-4                                     |
|             | 4.6 General ..... 4-4   |
| Section V   | Maintenance ..... 4-4   |
|             | 4.7 Operational checks ..... 4-4                              |
|             | 4.8 Document holder, replace..... 4-5                         |
|             | 4.9 Shelf support beams, replace..... 4-7                     |
|             | 4.10 Cleaning..... 4-8  |
|             | 4.11 Painting ..... 4-8                                       |
| Section VI  | Preparation for storage or shipment ..... 4-8                 |
|             | 4.12 General ..... 4-8  |
|             | 4.13 Special instructions for administrative storage..... 4-8 |

## SECTION I. LUBRICATION INSTRUCTIONS

### 4.1 LUBRICATION.

Lubrication is not required.

## SECTION II. SERVICE UPON RECEIPT

### 4.2 GENERAL.

4.2.1 Upon receipt of the container, open and close doors to ensure they operate freely. Refer to Paragraphs 2.7 and 2.10.

4.2.2 Check that the following components are available in correct quantities:

#### NOTE

**Shelves and shelf support beams are not included on containers with serial numbers TC0100263 or greater.**

- **Shelves, eight pieces.**
- **Shelf Support Beams, 12 left-hand pieces and 12 right-hand pieces. Left- and right-hand pieces will typically be assembled and installed in the containers.**
- **Connecting Link Assembly, three pieces. The link assemblies will be located in the tool box inside the right- hand door.**

## SECTION III. PREVENTIVE MAINTENANCE CHECKS AND SERVICES (PMCS)

### 4.3 GENERAL.

Preventive Maintenance Checks and Services (PMCS) means systematic caring, inspecting and servicing of equipment to keep it in good condition and to prevent breakdowns.

- a. Be sure to perform PMCS each time the container is operated.
- b. Do BEFORE (B) PMCS just before the container is operated. Pay attention to WARNINGS, CAUTIONS and NOTES.
- c. Use DA Form 2404 (Equipment Inspection and Maintenance Worksheet) to record any faults that you discover before, during, or after operation, unless you can fix them. You DO NOT need to record faults that you fix.
- d. Perform any other services when required by organizational maintenance.

**4.4 PMCS PROCEDURES.**

4.4.1 Your Preventive Maintenance Checks and Services, Table 4-1, lists inspections and care required to keep the container in good operating condition. It is set up so you can make your BEFORE (B) OPERATION checks as you walk around the container.

4.4.2 The Interval column of table 4-1 tells you when to do a certain check or service.

4.4.3 The Procedure column of table 4-1 tells you how to do required checks and services. Carefully follow these instructions.

**NOTE**

**Terms "ready/available" and "mission capable" refer to same status: Equipment is on hand and ready to perform its combat missions. (See DA PAM 738-750.)**

4.4.4 The Equipment Is Not Ready/Available column in table 4-1 tells you when your container is not mission capable and why the container cannot be used.

4.4.5 If the container does not perform as required, refer to Section IV, Troubleshooting.

4.4.6 If anything looks wrong and you cannot fix it, write it on your DA Form 2404 and immediately report it to your supervisor.

**4.5 PMCS TABLE.**

*Table 4-1. Unit Preventive Maintenance Checks and Services For Tricon Container*

**NOTE**

**All procedures should be performed both before and after the container is used.**

| Item Number | Interval | Location                          | Procedure   | Not Fully Mission Capable If:  |
|-------------|----------|-----------------------------------|---|--|
|             |          | Item to Check/ Service            |   |  |
| 1           | Before   | Container,<br>All panels          | Inspect side, front, and door panels for holes.   | Holes exist in any panels.   |
| 2           | Before   | Container,<br>All welds           | Inspect all welds at corners and along the corner posts. Inspect all welds that attach the lockrod assemblies to the door assembly. | Any welds are damaged.   |
| 3           | Before   | Door handles and related hardware | Inspect for any broken welds or defective parts. Operate handles.   | Handles or related hardware are broken or if handles will not open door. |
| 4           | Before   | Document holder                   | Inspect for any large dents that may prevent the holder from being completely opened or closed.                                     | Document holder cannot be completely opened or closed.                   |
| 5           | Before   | Shelf assembly                    | Inspect for cracked or broken welds.  | Any welds are cracked or broken.   |
| 6           | Before   | Support beams                     | Inspect support beams for complete welds and working clips.   | Any welds or clips are defective.  |
| 7           | Before   | Door seals                        | Inspect for tears.  | Door seals are torn.   |
| 8           | Before   | Vents                             | Inspect for broken vents.   | Vents are broken.  |



Table 4-1. Unit Preventive Maintenance Checks and Services For Tricon Container

| Item Number | Interval | Location                 | Procedure   | Not Fully Mission Capable If:             |
|-------------|----------|--------------------------|---|---|
|             |          | Item to Check/Service    |   |   |
| 9           | Before   | Connecting link assembly | Check that handle can be pulled out and shifted 90 degrees. | If handle is jammed or cannot be shifted. |

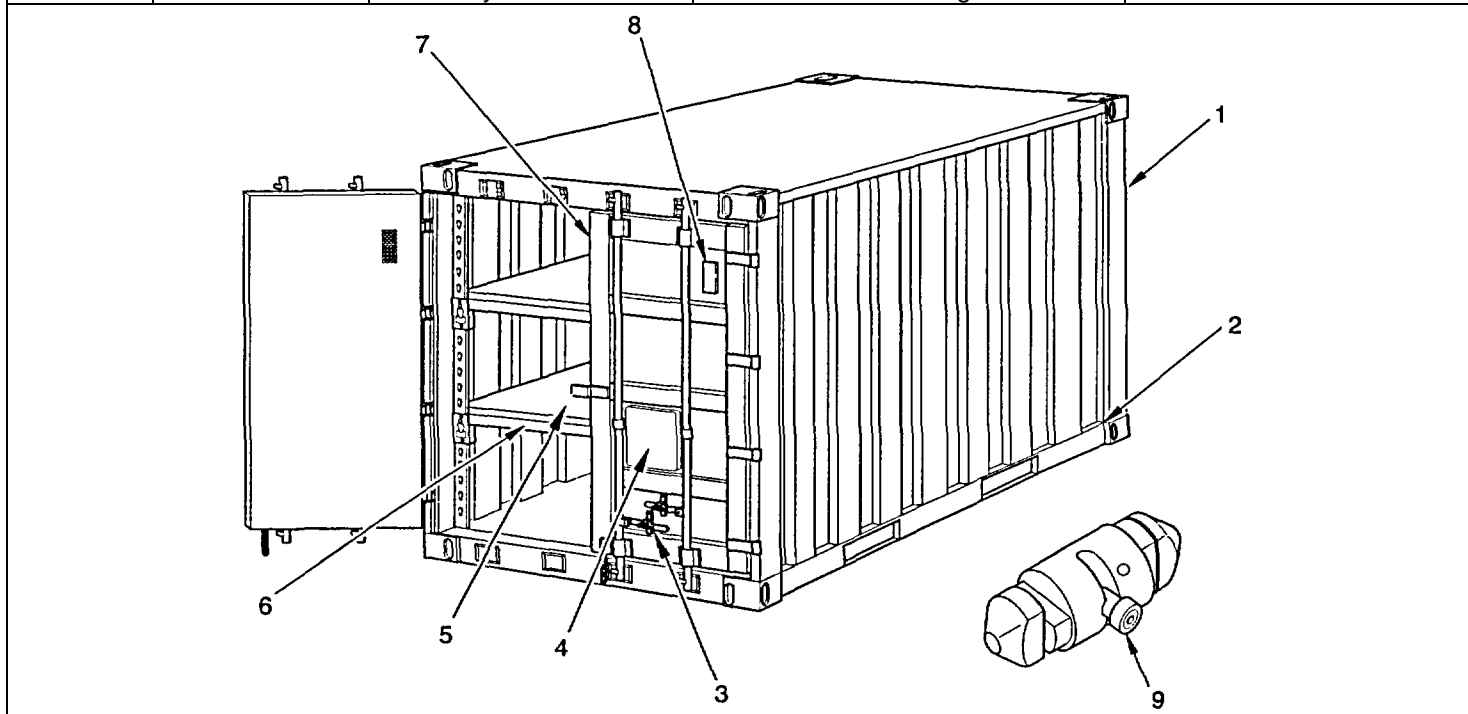

**SECTION IV. TROUBLESHOOTING**

**4.6 GENERAL.**

Unit troubleshooting procedures are the same as operator troubleshooting. Refer to Chapter 3, Section II.

**SECTION V. MAINTENANCE**

**4.7 OPERATIONAL CHECKS.**

Refer to operating procedures in Chapter 2, Section III for all operational checks.

**4.8 DOCUMENT HOLDER, REPLACE.**

This task covers: a. Removal                      b. Installation

**Initial Setup:**

Tools

7/16 inch socket wrench (Appendix B, Section III, Item 5)

Caulking gun (Appendix B, Section III, Item 3)

Materials/Parts Required

None

Equipment Condition

Right-hand door is open.

Both document holder doors are raised.

Personnel Required

2

a. Removal

- (1) Place 7/16 inch socket over one of the bolts (1) on the outside document holder (2).
- (2) Use another 7/16 inch socket to remove the corresponding nut (3) on the inside document holder (4).
- (3) Repeat Steps (1) and (2) at the three remaining attachment points.
- (4) Remove inside document holder (4), being careful not to lose the nine washers (5) that are on the lower bolts and the seven washers (6) that are on the upper bolts.

**NOTE**

**If only inside document holder is being replaced, proceed to installation procedures. If outside document holder is being replaced, continue with this procedure.**

- (5) Remove seven washers (6) from each of the upper bolts.
- (6) Remove nine washers (5) from each of the lower bolts.
- (7) Remove all four bolts (1) and washers (7) from the outside document holder (2).

**NOTE**

**Outside document holder (2) may remain adhered to door by beads of silicone.**

- (8) Remove outside document holder (2) from door.

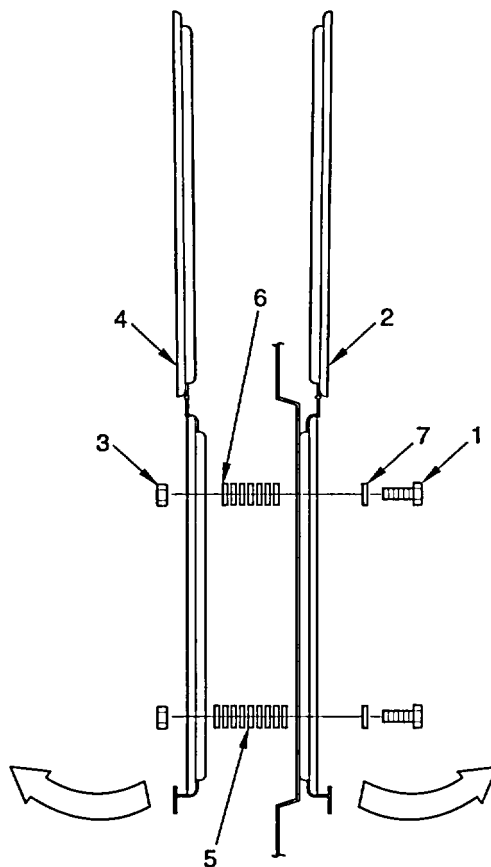

b. Installation

**NOTE**

**The process below includes installation of the outside document holder. If only the inside holder is being installed, the outside holder will still be in place on the door and the process can start with Step 3.**

- (1) Apply a thin bead of silicone (Item 1, Appendix F) on the back of the document holder around each of the four mounting holes.

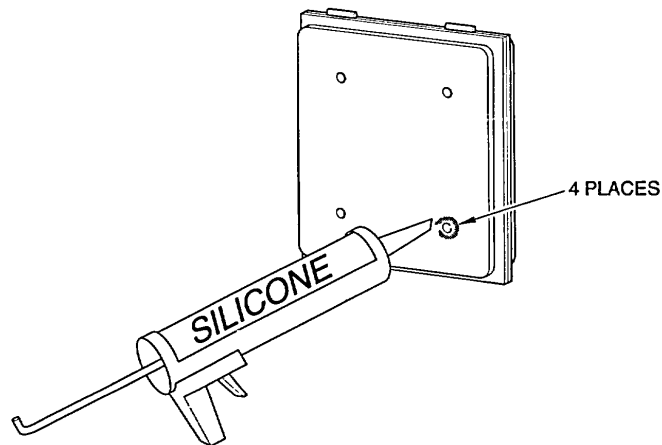

- (2) Position outside document holder (1) over holes in doors and insert four bolts (2) with one washer (3) each through the holders and the door.
- (3) Install seven washers (4) over each of the two upper bolts on the inside of the door.
- (4) Install nine washers (5) over each of the two lower bolts on the inside of the door.
- (5) Position inside document holder (6) over bolts (2), being careful not to lose washers (4 and 5).
- (6) Install four nuts (7) over the bolts on the inside document holder.
- (7) Hold bolt heads with 7/16-inch socket or socket and torque nuts to a maximum of 2 ft/lbs.
- (8) Close both document holders.
- (9) Paint new document holder (refer to Paragraph 4.11)
- (10) Close right-hand door.

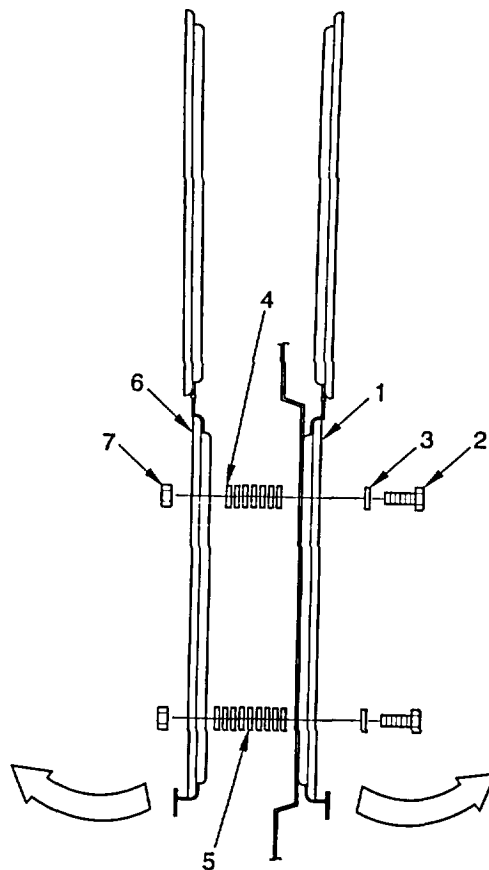

**4.9 SHELF SUPPORT BEAMS, REPLACE.**

This task covers: a. Removal                      b. Installation

**Initial Setup:**

Tools

None

Materials/Parts Required

None

Equipment Condition

Container doors are open.

Personnel Required

2

**NOTE**

**This procedure applies to either right-hand or left-hand shelf support beams.**

a. Removal

- (1) Remove any shelves that block access to the damaged shelf support beam.
- (2) Release locking clips (1) from the vertical shelf supports (2) on both sides of the damaged beam (3). Push both sides of the beam up to release the rivets (4) from the vertical shelf supports (2).
- (3) Remove damaged right or left-hand support beam.

b. Installation

- (1) Slide new support beam on mating right or left-hand support beam.
- (2) Position the beam at the same height as the other beams that support the same shelves.
- (3) Slide ends outward until the rivets (4) on the ends align with the tear-drop cutouts in the vertical shelf support (2).
- (4) Pull out spring clips (1) and insert rivets (4) into the tear-drop cutouts. Slide both ends down to engage rivets (4) with the vertical shelf support (2). Release spring clips (1) to lock the beam supports in place.

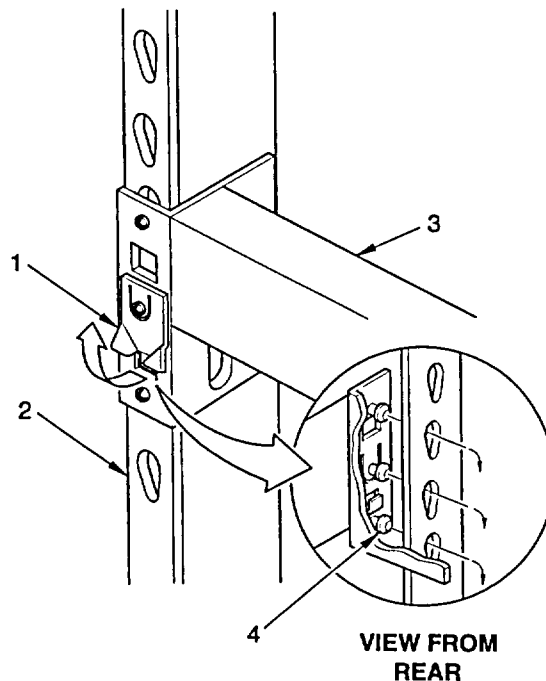

**4.10 CLEANING.****WARNING**

**Some cleaning compounds may have hazardous fumes or skin irritants. Failure to observe any warning may cause personal injury or death. Follow all recommended procedures when using any cleaning compound.**

4.10.1 Exterior.

The exterior of the container may be cleaned with soap and water, high-pressure hose or any readily available cleaning compound. If cleaning compounds are used, follow all recommended handling procedures.

4.10.2 Interior.

Shipping debris and accumulated dirt should be swept out of the containers after each use. It may be useful to remove some shelves and shelf supports to make cleaning easier. After sweeping, use soap and water, high-pressure hose or any cleaning compound to clean the interior. When using any cleaning compound, be sure to follow all recommended handling procedures.

**4.11 PAINTING.**

If required, paint exterior of container with CARC paint in accordance with TM 43-0139.

**SECTION VI. PREPARATION FOR STORAGE OR SHIPMENT****4.12 GENERAL.**

No special instructions are required for storage or shipment. Refer to Operation Under Usual Conditions in Chapter 2, Section III.

**4.13 SPECIAL INSTRUCTIONS FOR ADMINISTRATIVE STORAGE.**

4.13.1 Placement of equipment in administrative storage should be for short periods of time when a shortage of maintenance effort exists. Items should be in mission readiness within 24 hours or within the time factors as determined by the directing authority. During the storage period, appropriate maintenance records shall be kept.

4.13.2 Before placing the equipment in administrative storage, current preventive maintenance checks and services should be completed, shortcomings and deficiencies should be corrected, and all Modification Work Orders (MWO) should be applied.

4.13.3 Storage site selection. Inside storage is preferred for items selected for administrative storage. If inside storage is not available, trucks, vans, conex containers, and other containers may be used.

CHAPTER 5

DIRECT SUPPORT MAINTENANCE INSTRUCTIONS

|             | Page  |
|-------------|---|
| Section I   | Lubrication instructions..... 5-2                           |
|             | 5.1 Lubrication ..... 5-2                                   |
| Section II  | Service upon receipt ..... 5-2                              |
|             | 5.2 General ..... 5-2                                       |
| Section III | Preventive maintenance checks and services (PMCS) ..... 5-2 |
|             | 5.3 General ..... 5-2                                       |
|             | 5.4 PMCS procedures ..... 5-2                               |
|             | 5.5 PMCS table ..... 5-3                                    |
| Section IV  | Troubleshooting ..... 5-4                                   |
|             | 5.6 Introduction ..... 5-4                                  |
|             | 5.7 Cargo is damaged by weather ..... 5-4                   |
|             | 5.8 Cargo is damaged by movement..... 5-5                   |
|             | 5.9 Doors do not close ..... 5-5                            |
|             | 5.10 Doors do not open ..... 5-6                            |
|             | 5.11 Documents are damaged ..... 5-6                        |
|             | 5.12 Containers cannot be coupled..... 5-6                  |
| Section V   | Maintenance ..... 5-7                                       |
|             | 5.13 Operational checks ..... 5-7                           |
|             | 5.14 Seal set, replace ..... 5-7                            |
|             | 5.15 Ventilator, replace ..... 5-12                         |
|             | 5.16 Replacing welded parts ..... 5-13                      |
|             | 5.17 Repairing welds ..... 5-14                             |
|             | 5.18 Repairing holes and cracks ..... 5-14                  |
|             | 5.19 Cleaning..... 5-14                                     |
|             | 5.20 Painting ..... 5-14                                    |
| Section VI  | Preparation for storage or shipment ..... 5-14              |
|             | 5.21 General ..... 5-14                                     |

## SECTION I. LUBRICATION INSTRUCTIONS

### 5.1 LUBRICATION.

Lubrication is not required.

## SECTION II. SERVICE UPON RECEIPT

### 5.2 GENERAL.

5.2.1 Upon receipt of the container open and close doors to ensure they operate freely. Refer to Paragraphs 2.7 and 2.10.

5.2.2 Check that the following components are available in correct quantities:

#### NOTE

**Shelves and shelf support beams are not included on containers with serial numbers TC0100263 or greater.**

- **Shelves, eight pieces.**
- **Shelf Support Beams, 12 left-hand pieces and 12 right-hand pieces. Left and right-hand pieces will typically be assembled and installed in the container.**
- **Connecting Link Assembly, three pieces. The link assemblies will be located in the tool box inside the right-hand door.**

## SECTION III. PREVENTIVE MAINTENANCE CHECKS AND SERVICES (PMCS)

### 5.3 GENERAL.

Preventive Maintenance Checks and Services (PMCS) means systematic caring, inspecting and servicing of equipment to keep it in good condition and to prevent breakdowns.

- a. Be sure to perform PMCS each time the container is operated.
- b. Do BEFORE (B) PMCS just before the container is operated. Pay attention to WARNINGS, CAUTIONS and NOTES.
- c. Use DA Form 2404 (Equipment Inspection and Maintenance Worksheet) to record any faults that you discover before, during, or after operation, unless you can fix them. You DO NOT need to record faults that you fix.
- d. Perform any other services when required by organizational maintenance.

### 5.4 PMCS PROCEDURES.

5.4.1 Your Preventive Maintenance Checks and Services, Table 5-1, lists inspections and care required to keep the container in good operating condition. It is set up so you can make your BEFORE (B) OPERATION checks as you walk around the container.

5.4.2 The Interval column of table 5-1 tells you when to do a certain check or service.

5.4.3 The Procedure column of table 5-1 tells you how to do required checks and services. Carefully follow these instructions.

**NOTE**

**Terms "ready/available" and "mission capable" refer to same status: Equipment is on hand and ready to perform its combat missions. (See DA PAM 738-750.)**

5.4.4 The Equipment Is Not Ready/Available column in table 5-1 tells you when your container is not mission capable and why the container cannot be used.

5.4.5 If the container does not perform as required, refer to Section IV, Troubleshooting.

5.4.6 If anything looks wrong and you cannot fix it, write it on your DA Form 2404 and immediately report it to your supervisor.

**5.5 PMCS TABLE.**

*Table 5-1. Preventive Maintenance Checks and Services For Tricon Container*

**NOTE**

**All procedures should be performed both before and after the container is used.**

| Item Number | Interval | Location                 | Procedure   | Not Fully Mission Capable If: |
|-------------|----------|--------------------------|---|-------------------------------|
|             |          | Item to Check/ Service   |   |                               |
| 1           | Before   | Container,<br>All panels | Inspect side, front, and door panels for holes.   | Holes exist in any panels.    |
| 2           | Before   | Container,<br>All welds  | Inspect all welds at corners and along the corner posts. Inspect all welds that attach the lockrod assemblies to the door assembly. | Any welds are damaged.        |

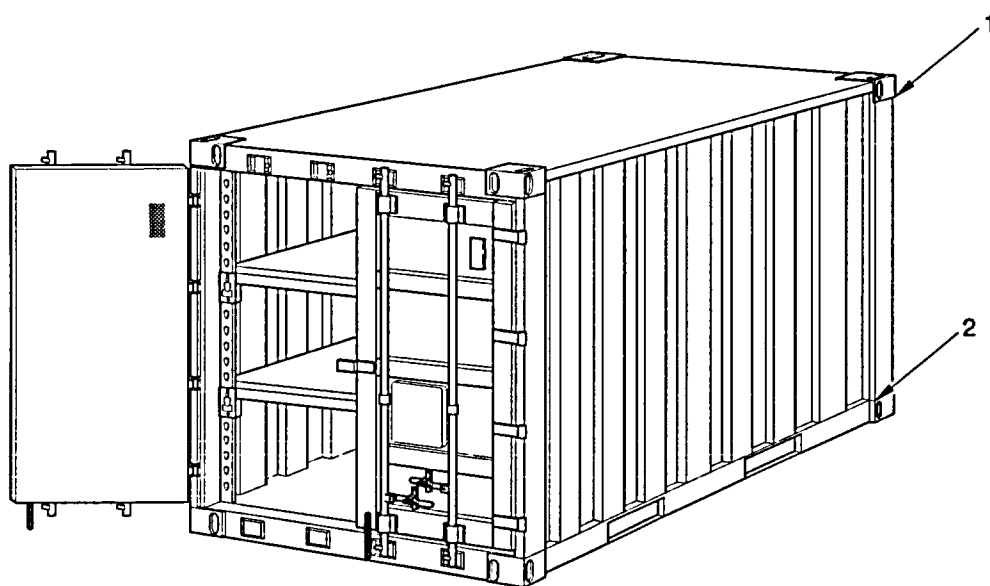



SECTION IV. TROUBLESHOOTING

Malfunction Index

|                                    | Troubleshooting Procedure (Para) |
|------------------------------------|----------------------------------|
| Cargo is damaged by weather .....  | 5.7                              |
| Cargo is damaged by movement ..... | 5.8                              |
| Doors do not close .....           | 5.9                              |
| Doors do not open .....            | 5.10                             |
| Documents are damaged .....        | 5.11                             |
| Containers cannot be coupled ..... | 5.12                             |

**5.6 INTRODUCTION.**

The troubleshooting tables in Paragraphs 5.7 through 5.12 list the common malfunctions that may occur. Perform the procedures in the order that they appear in the tables.

**5.7 CARGO IS DAMAGED BY WEATHER.**

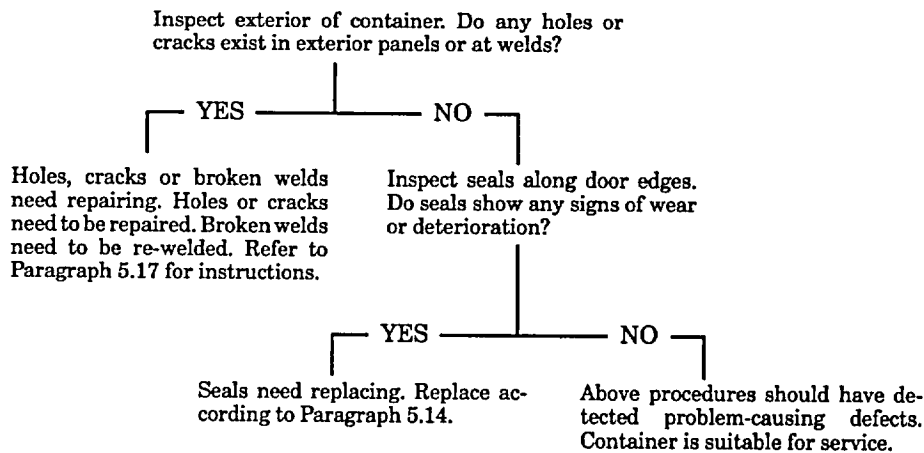

**5.8 CARGO IS DAMAGED BY MOVEMENT.**

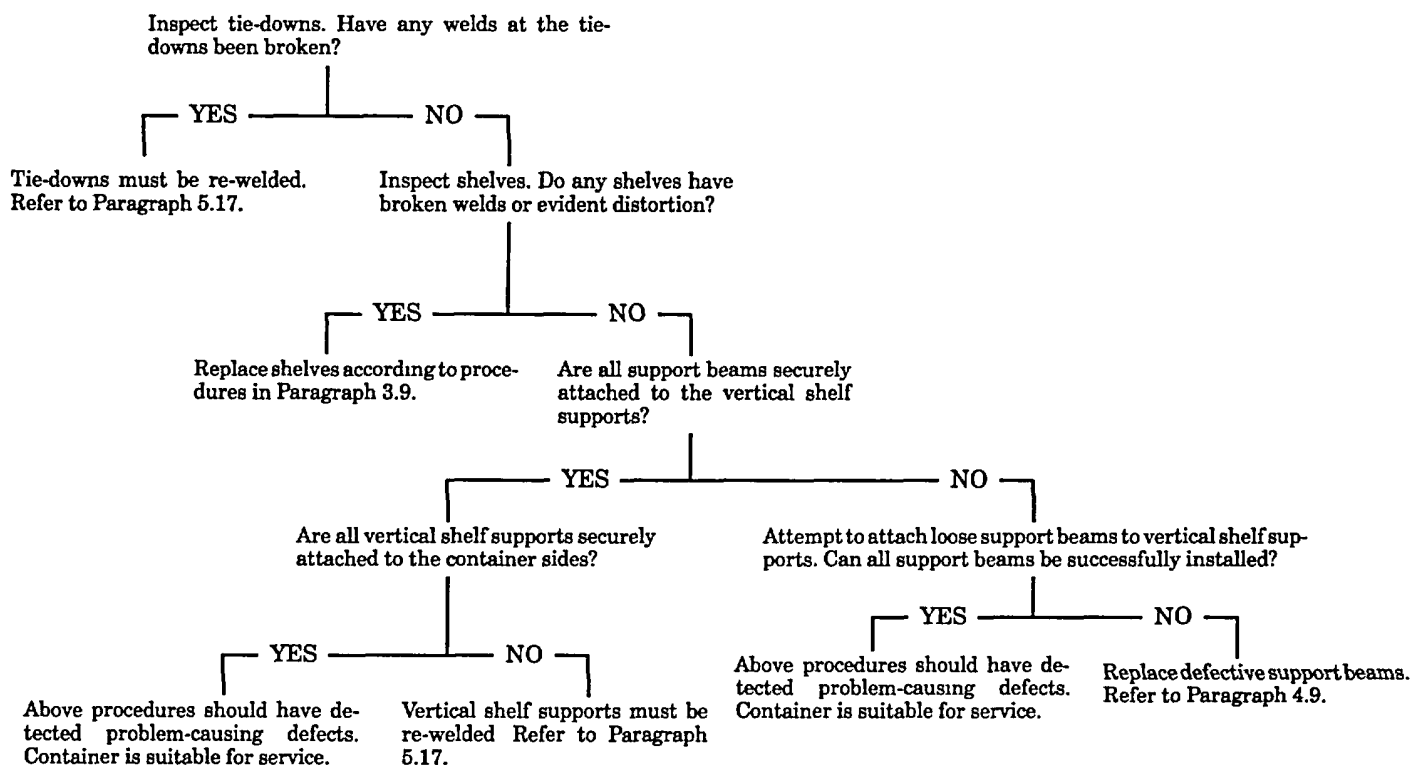

**5.9 DOORS DO NOT CLOSE.**

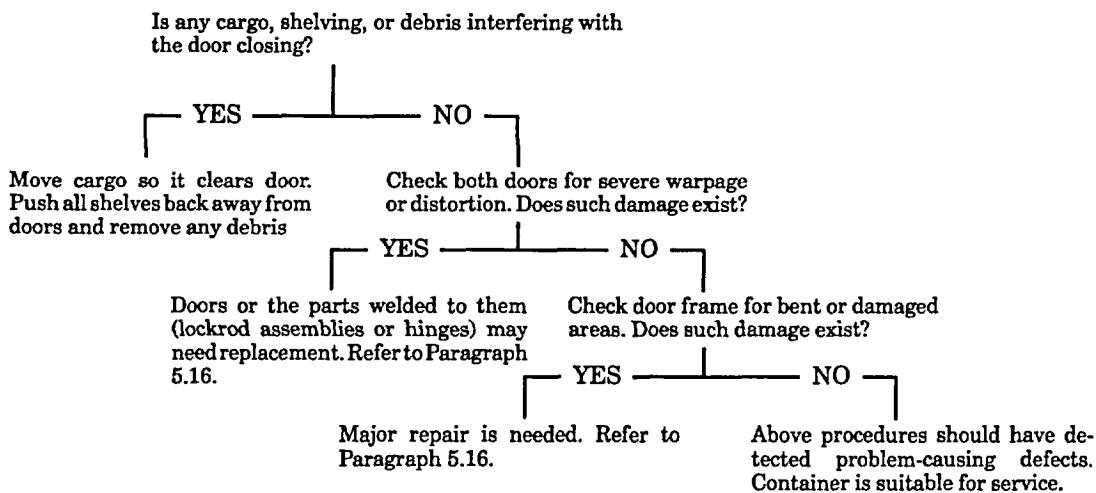

**5.10 DOORS DO NOT OPEN.**

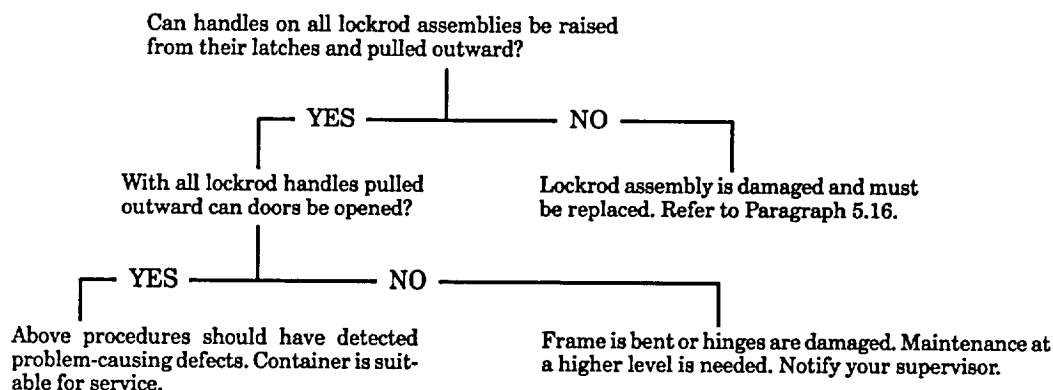

**5.11 DOCUMENTS ARE DAMAGED.**

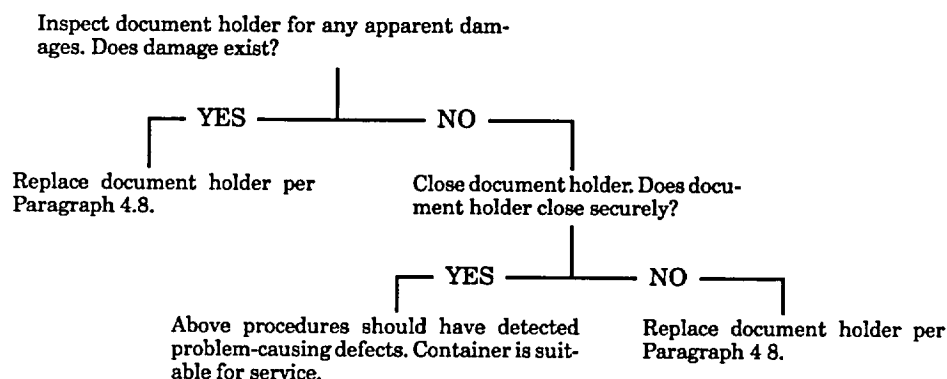

**5.12 CONTAINERS CANNOT BE COUPLED.**

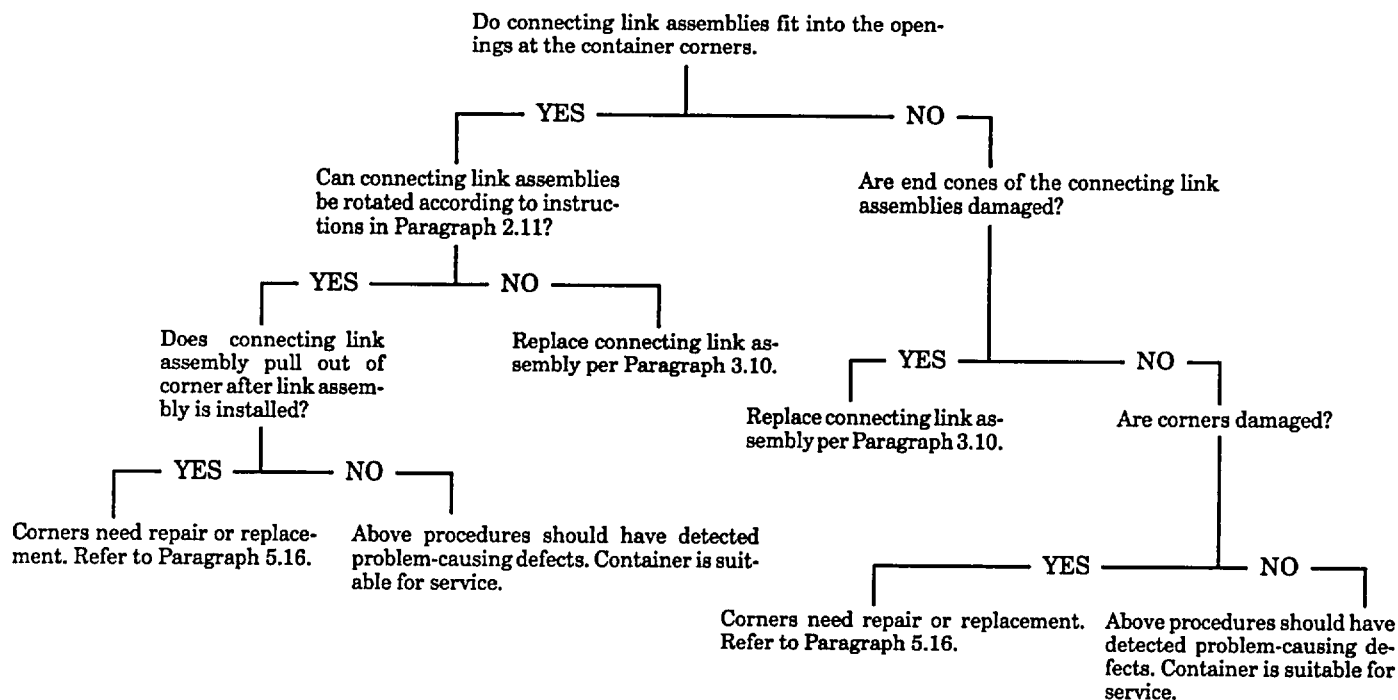

**SECTION V. MAINTENANCE**

**5.13 OPERATIONAL CHECKS.**

Refer to operating procedures in Chapter 2, Section III for all operational checks.

**5.14 SEAL SET, REPLACE.**

This task covers: a. Removal                      b. Installation

**Initial Setup:**

|  |                            |
|--|----------------------------|
| <u>Tools</u>                                   | <u>Equipment Condition</u> |
| Caulk gun (Appendix B, Section III, Item 3)    | Both doors are open.       |
| Hand drill (Appendix B, Section III, Item 1)   |                            |
| Hand grinder (Appendix B, Section III, Item 2) |                            |
| Rivet tool (Appendix B, Section III, Item 4)   | <u>Personnel Required</u>  |
| <u>Materials/Parts Required</u>                |                            |
| Pencil   | 2                          |

a. Removal

**WARNING**

**To gain access to the seals on the bottom door edge, it may be necessary to raise the container above floor level. Use lifting devices rated for a minimum of 10,000 pounds (4536 Kg). Using less than rated equipment could expose personnel to serious injury or death.**

**NOTE**

**Original seals are installed using nails. When seals are replaced, stainless steel rivets are used.**

Removal of the seals is the same for both left- and right-hand doors.

- (1) Grind the heads off of all the nails (1) or rivets. There are six on each top and bottom edge and 10 on each side edge.

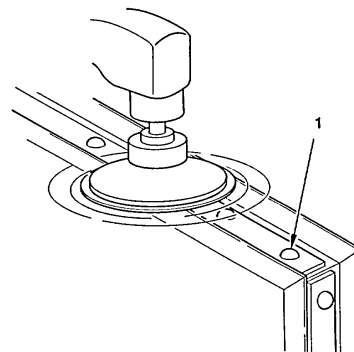

- (2) Remove all short carriers (1) and long carriers (2). The right-hand door has carriers on all four door edges. The left-hand door does not have a carrier or seal on the edge that mates with the right-hand door.
- (3) Remove and discard all seals (3).

b. Installation

- (1) Using a pencil, mark the positions on the carriers where the new rivets will be installed. Proper location for the holes for the short and long carriers is as follows:

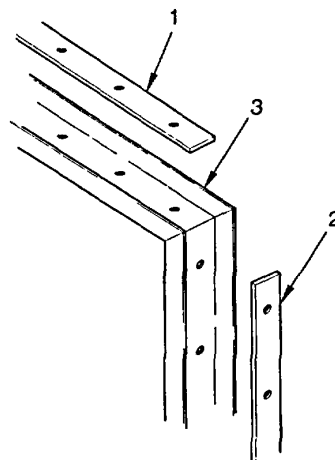

**NOTE**

· The dimensions given below are approximate. The goal of the steps is to mark the spot where the rivets will be installed. It is important that the desired number of spots are shown. It is not a problem if the spacing between the spots is not uniform. Some marks may need to be moved slightly in order to avoid existing nail (or rivet) locations.

· Make sure the marks are centered as much as possible between the edges of the carriers.

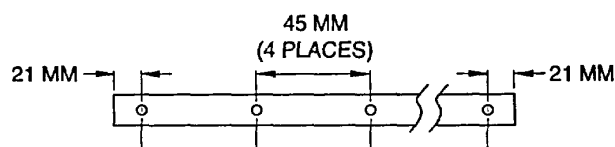

**TOP AND BOTTOM CARRIERS (SHORT)**

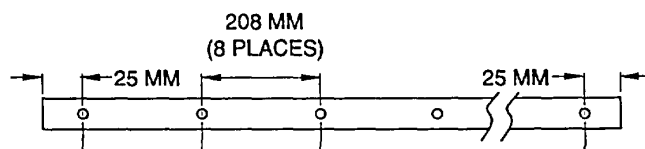

**EDGE CARRIER (LONG)**

- (a) For the short carriers, mark a spot approximately 21 mm (0.83 inches) from each end. Then mark four more spots approximately 145 mm (5.7 inches) apart. Each carrier should have six spots fairly equally spaced.
- (b) For the long carriers, mark a spot approximately 25 mm (1 inch) from each end. Then mark eight more spots approximately 208 mm (8.18 inches) apart. Each carrier should have 10 spots fairly equally spaced.

- (2) Position one of the long carriers along the outside edge of the left-hand door next to the row of nails. The carrier should not extend beyond either door end.
- (3) Mark each end of the carrier in order to maintain the same orientation during final installation.
- (4) Compare the marks on the carrier (1) to the nail (2) (or rivet) stubs on the edge of the door. If any of the marks are located too close (within 1/4 inch) to a nail (or rivet), cross that mark out and make another one further away from the existing stub. Keeping a minimum distance between the new drill mark and old nail (or rivet) locations ensures that the drill bit will not bind.
- (5) Position one of the short carriers along the top edge of the door next to the row of nails.

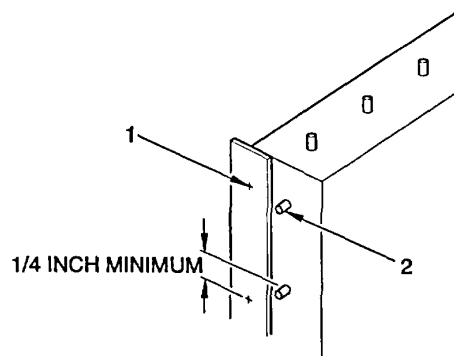

- (6) Repeat Steps (3) and (4) for the short carrier.
- (7) Position one of the short carriers along the bottom edge of the door. Repeat Steps (3) and (4).
- (8) Repeat Steps (2) through (5) for the right-hand door carriers.
- (9) When all the carriers have been marked and compared to existing nail (or rivet) locations, grind the nails (1) (or rivets) further so the shafts of the nails (or rivets) are flush with the edge of the door.

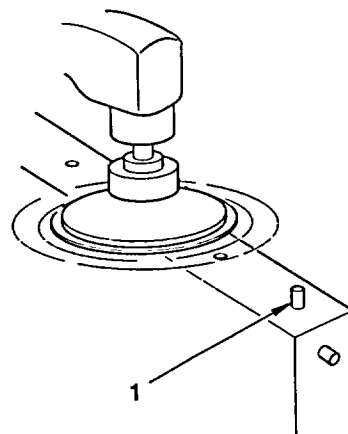

- (10) Stretch the C-shaped seal (1) over the left-hand door's outside edge (2). Make sure seal is orientated so the large, curved lip of the seal is on the outside portion of the door.

**NOTE**

**Installation of the carriers must be completed before polyurethane sealant is allowed to dry.**

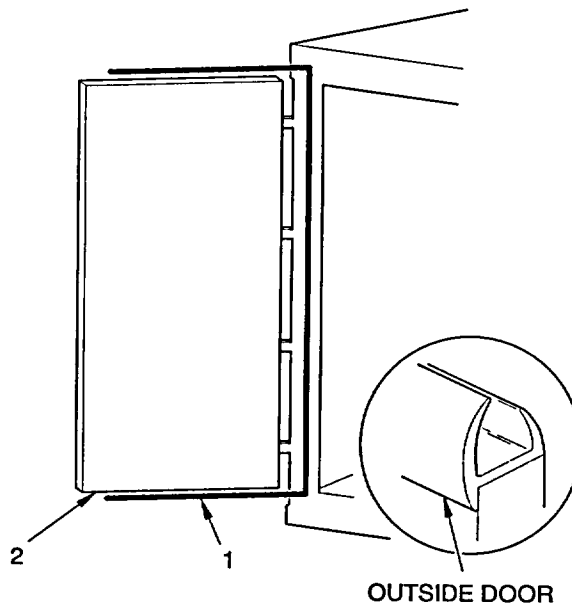

- (11) Starting from about eight inches above the inside bottom edge of the left door, apply a 1/8 inch bead of polyurethane sealant (1) (Item 2, Appendix G) along the seal (2). Continue the application to the end of the seal.

**NOTE**

**Be sure to use the marks previously made in Step (3) to orient the carriers prior to installation. The orientation of the carriers should be the same as when they were marked.**

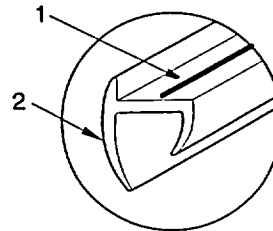
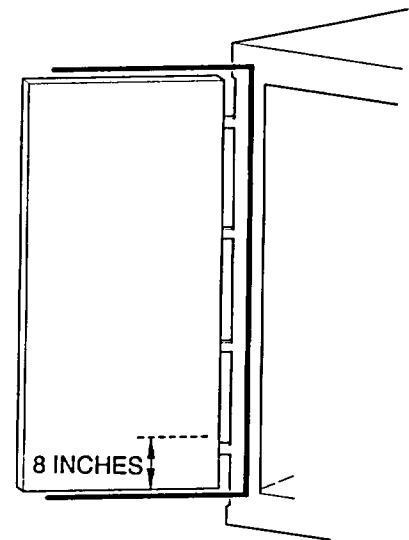

- (12) Hold the appropriate long carrier (1) in position against the seal (2).
- (13) Drill a 3/16 inch hole for the rivet through the carrier (1), seal (2), and door at the two end marks on the carrier.
- (14) Install a rivet in each end of the carrier; then one in the center. Work from the center towards each end to install the remaining rivets.
- (15) Install the top of the seal over the door, gently pulling the seal toward the inside door edge. The seal will extend beyond the inside door edge. This excess will be trimmed later.
- (16) Position the appropriate short carrier along the top edge of the door.
- (17) Repeat Steps (12), (13), and (14) for the short carrier.
- (18) Repeat Steps (16) and (17) for the bottom edge of the door.

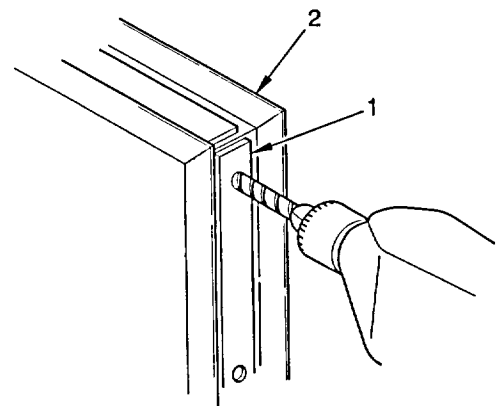

- (19) At top and bottom of door, trim the ends of the seal (1) so they are flush with the inside edge of the door.

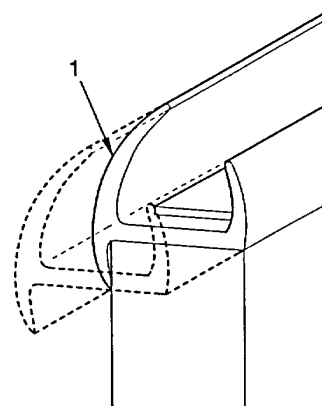

- (20) Stretch the rectangular seal (1) around the right-hand door (2). Make sure the large curved lip of the seal is on the outside portion of the door.
- (21) Pull the seal (1) away from the bottom edge of the door (2) allowing access to the inside edge of the seal.

**NOTE**

**Installation of the carriers must be complete before polyurethane is allowed to dry.**

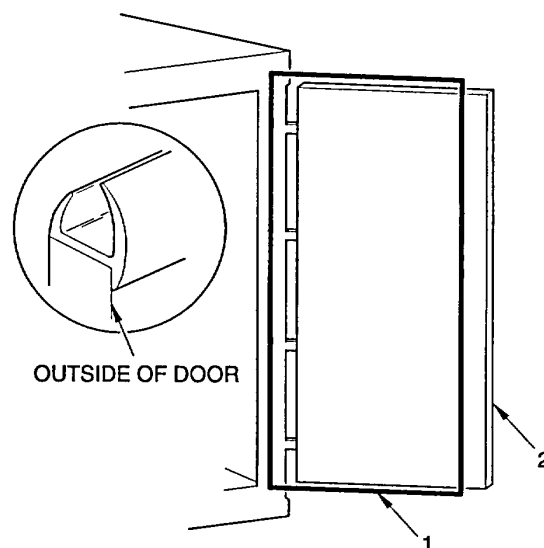

- (22) Starting from about eight inches above the inside bottom edge of the door, apply a 1/8 inch bead of polyurethane sealant (3) (Item 2, Appendix G) along the middle of the seal facing the edge of the door. Continue the application to the other side of the seal and up the edge for about another eight inches.
- (23) Install the seal around the bottom edge of the door.
- (24) Position the appropriate long carrier along the outside edge of the right-hand door.
- (25) Repeat Steps (13) and (14) for the long carriers on each side of the door.
- (26) Position the appropriate long carrier along the inside edge of the right-hand door.
- (27) Repeat Steps (13) and (14) for the long carrier.

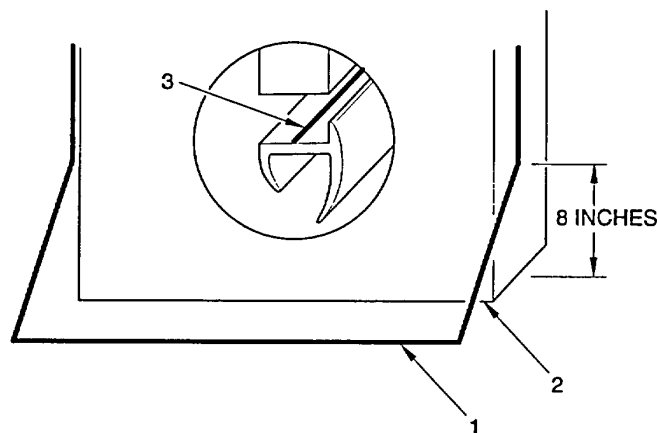



- (28) Position the appropriate short carrier along the top edge of the door.
- (29) Repeat Steps (13) and (14) for the short carrier.
- (30) Position the last short carrier along the bottom edge of the right-hand door.
- (31) Repeat Steps (13) and (14) for the short carrier.

**5.15 VENTILATOR, REPLACE.**

This task covers: a. Removal                      b. Installation

**Initial Setup:**

| <u>Tools</u>                                 | <u>Materials/Parts</u>     |
|--|----------------------------|
| Hand drill (Appendix B, Section III, Item 1) | None                       |
| Caulk gun (Appendix B, Section III, Item 3)  | <u>Equipment Condition</u> |
| Rivet tool (Appendix B, Section III, Item 4) | N/A                        |

a. Removal

- (1) Use a 3/16 inch drill to remove the four rivets at the corners of the ventilators. Some ventilators may only have three rivets.
- (2) Remove and discard damaged ventilator.

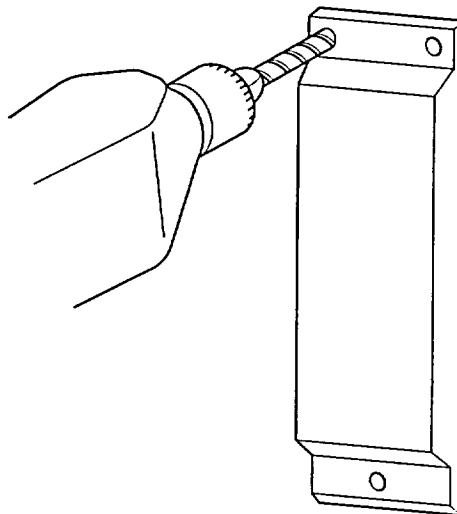

b. Installation

- (1) If the old ventilator had three holes, position the new ventilator (1) over the holes and install rivets in each hole (2).
- (2) If the old ventilator had four holes, proceed as follows:
  - (a) Position the top two ventilator holes over the top two existing holes and secure the ventilator with rivets.
  - (b) Drill a new 3/16 inch hole through the door using the lower ventilator hole as a guide.
  - (c) Install a rivet in the lower hole.
- (3) Apply silicone (3) (Item 1, Appendix G) around ventilator/door seam along both sides and the top.
- (4) Paint with CARC paint as per Paragraph 5.20.

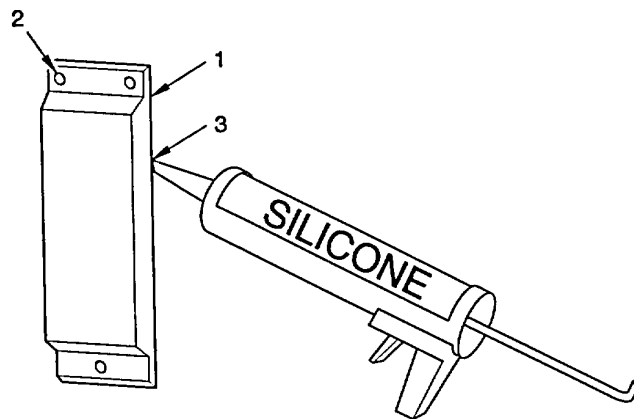
**5.16 REPLACING WELDED PARTS.****Initial Setup:**Materials/Parts

Refer to TC 9-237.

**WARNING**

**Welding over or around CARC painted surfaces will create dangerous gases which are hazardous to the operator's health. Operators must use proper OSHA approved respirators and equipment while repairs are made. Prior to welding on this equipment, refer to MIL-C-53072 Chemical Agent Resistant Coating (CARC) System Application Procedures and Quality Control Inspection.**

The majority of parts on the container are welded. To replace these parts, follow procedures in TC 9-237 for welding. The container is painted with CARC paint. Refer to TM 43-0139 for proper paint removal and preparation for painting procedures.

**5.17 REPAIRING WELDS.**

---

**Initial Setup:**Materials/Parts

Refer to TC 9-237.

---

**WARNING**

**Welding over or around CARC painted surfaces will create dangerous gases which are hazardous to the operator's health. Operators must use proper OSHA approved respirators and equipment while repairs are made. Prior to welding on this equipment, refer to MIL-C-53072 Chemical Agent Resistant Coating (CARC) System Application Procedures and Quality Control Inspection.**

If a weld shows signs of cracking or separation, the weld must be replaced. Refer to TC 9-237 for proper welding procedures. The container is painted with CARC paint. Refer to TM 43-0139 for proper paint removal and preparation for painting procedures.

**5.18 REPAIRING HOLES AND CRACKS.**

---

**Initial Setup:**Materials/Parts

Refer to TC 9-237.

---

**WARNING**

**Welding over or around CARC painted surfaces will create dangerous gases which are hazardous to the operator's health. Operators must use proper OSHA approved respirators and equipment while repairs are made. Prior to welding on this equipment, refer to MIL-C-53072 Chemical Agent Resistant Coating (CARC) System Application Procedures and Quality Control Inspection.**

Holes or cracks in large panels may be repaired by patching the hole by welding a new piece rather than replacing the entire panel. Refer to TC 9-237 for welding procedures. The container is painted with CARC paint. Refer to TM 43-0139 for proper paint removal and preparation for painting procedures.

**5.19 CLEANING.**

Refer to Chapter 4, Paragraph 4.10 for cleaning instructions.

**5.20 PAINTING.**

The container requires paint that is classified as Chemical Agent Resistant Coating (CARC) paint. For proper painting procedures refer to TM 43-0139.

**SECTION VI. PREPARATION FOR STORAGE OR SHIPMENT**

**5.21 GENERAL.**

Refer to Section VI in Chapter 4.

**APPENDIX A**

**REFERENCES**

A-1 SCOPE.

This appendix lists all forms, field manuals, technical manuals, and specifications referenced in this manual.

A-2 FORMS.

|  |              |
|--|--------------|
| Product Quality Deficiency Report .....                | SF 368       |
| Equipment, Inspection, and Maintenance Worksheet ..... | DA Form 2404 |

A-3 FIELD MANUALS.

|                              |          |
|------------------------------|----------|
| NBC Decontamination .....    | FM 3-5   |
| First Aid for Soldiers ..... | FM 21-11 |

A-4 TECH MANUALS.

|   |              |
|---|--------------|
| Destruction of Material .....               | TM 750-244-3 |
| Use of Chemical Agent Resistant Paint ..... | TM 43-0139   |

A-5 TRAINING CIRCULARS

|                                      |          |
|--------------------------------------|----------|
| Welding Theory and Application ..... | TC 9-237 |
|--------------------------------------|----------|

A-6 SPECIFICATIONS

|   |             |
|---|-------------|
| Chemical Agent Resistant Coating (CARC) System Application<br>Procedures and Quality Control Inspection ..... | MIL-C-53072 |
|---|-------------|

## APPENDIX B

## MAINTENANCE ALLOCATION CHART (MAC)

## SECTION I. INTRODUCTION

**B-1 GENERAL.**

- a. This Appendix provides a general explanation of all maintenance and repair functions authorized at various maintenance levels for the Tricon Container.
- b. The Maintenance Allocation Chart (MAC) in Section II designates overall authority and responsibility for the performance of maintenance functions on the identified end item or component. The application of the maintenance functions to the end item or component will be consistent with the capacities and capabilities of the designated maintenance levels.
- c. Section III lists the tools and test equipment (both special tools and common tool sets) required for each maintenance function as referenced from Section II.
- d. Section IV contains supplemental instructions and explanatory notes for a particular maintenance function.

**B-2 MAINTENANCE FUNCTIONS.**

Maintenance functions for this equipment will be limited to and defined as follows:

- a. Inspect. To determine the serviceability of an item by comparing its physical and mechanical characteristics with established standards through examination.
- b. Test. To verify serviceability and to detect incipient failure by measuring the mechanical and/or electrical characteristics of an item and comparing those characteristics with prescribed standards.
- c. Service. Operations required periodically to keep an item in proper operating condition, i.e., to clean (includes decontaminate, when required), preserve, drain, paint, or to replenish fuel, lubricants, chemical fluids, or gases.
- d. Adjust. Maintain or regulate within prescribed limits, by bringing in to proper or exact position, or by setting the operating characteristics to the specified parameters.
- e. Align. To adjust specified variable elements of an item to bring about optimum or desired performance.
- f. Calibrate. To determine and cause corrections to be made by adjustment or alignment on instruments or test measuring and diagnostic equipment used in precision measurement. This consists of comparisons of two instruments, one of which is a certified standard of known accuracy, to detect and adjust any discrepancy in the accuracy of the instrument being compared.
- g. Remove/Install. To remove and install the same item when required to perform service or other maintenance functions. Install may be the act of emplacing, seating, or fixing into position an item, part, or module (component or assembly) in a manner to allow the proper functioning of the equipment or system.
- h. Replace. To remove an unserviceable item and install a serviceable counterpart in its place. Replace is authorized by the MAC and is shown as the third position code of the SMR code.
- i. Repair. The application of maintenance services (inspect, test, service, adjust, align, calibrate, and/or replace) including fault location/troubleshooting, removal/installation, and disassembly/assembly procedures, and maintenance actions (welding, grinding, riveting, straightening, facing, remachining, or resurfacing) to identify troubles and restore serviceability to an item by correcting specific damage, fault, malfunction, or failure in a part, subassembly, module (component or assembly), end item, or system.

**B-3 EXPLANATION OF COLUMNS IN THE MAC, SECTION II.**

- a. Column 1, Group Number. Column 1 lists functional group code numbers, the purpose of which is to identify maintenance significant components, assemblies, subassemblies, and modules with the next higher assembly. End item group number shall be "00".

- b. Column 2, Component/Assembly. Column 2 contains the noun names of components, assemblies, subassemblies, and modules for which maintenance is authorized.
- c. Column 3, Maintenance Function. Column 3 lists the functions to be performed on the item listed in Column 2. Functions are defined in paragraph B-2.
- d. Column 4, Maintenance Level. Column 4 specifies, by the listing of a work time figure in the appropriate subcolumn(s), the level of maintenance authorized to perform the function listed in Column 3. This figure represents the active time required to perform that maintenance function at the indicated level of maintenance. If the number or complexity of the tasks within the listed maintenance function vary at different levels, appropriate work time figures will be shown for each level. The work time figure represents the average time required to restore an item (assembly, subassembly, component, module, end item, or system) to a serviceable condition under typical field operating conditions. This time includes preparation time (including any necessary disassembly/assembly time), troubleshooting/fault location time, and quality assurance/quality control time in addition to the time required to perform the specific tasks identified for the maintenance functions authorized in the MAC. The symbol designations for the various maintenance levels are as follows:

- C - Operator/Crew (Unit)
- O - Organizational Maintenance (Unit)
- F - Direct Support Maintenance
- H - General Support Maintenance
- D - Depot Maintenance

- e. Column 5, Tools and Equipment. Column 5 specifies, by code, those common tool sets, individual tools, TMDE, and support equipment required to perform the designated function.
- f. Column 6, Remarks. This column shall, when applicable, contain a letter code, in alphabetical order, which shall be keyed to the remarks contained in Section IV

**B-4 EXPLANATION OF COLUMNS IN TOOL AND TEST EQUIPMENT REQUIREMENTS, SECTION III.**

- a. Column 1, Reference Code. The tool and test equipment reference code correlates with a code used in the MAC, Section II, Column 5.
- b. Column 2, Maintenance Level. The lowest category of maintenance authorized to use the tool or test equipment.
- c. Column 3, Nomenclature. Name or identification of the tool or test equipment.
- d. Column 4, National Stock Number. The National Stock Number of the tool or test equipment.
- e. Column 5, Tool Number. The manufacturer's part number.

**B-5 EXPLANATION OF COLUMNS IN REMARKS, SECTION IV**

- a. Column 1, Reference Code. The code recorded in Column 6, Section II.
- b. Column 2, Remarks. This column lists information pertinent to the maintenance function being performed as indicated in the MAC, Section II.

**SECTION II. MAINTENANCE ALLOCATION CHART  
FOR  
TRICON ASSEMBLY**

| (1)<br>Group<br>Number | (2)<br>Component/<br>Assembly | (3)<br>Maintenance<br>Function | (4)<br>Maintenance Level |     |                   |                    |       | (5)<br>Tools<br>and<br>Equip. | (6)<br>Remarks |
|------------------------|-------------------------------|--------------------------------|--------------------------|-----|-------------------|--------------------|-------|-------------------------------|----------------|
|                        |                               |                                | Unit                     |     | Direct<br>Support | General<br>Support | Depot |                               |                |
|                        |                               |                                | C                        | O   | F                 | H                  | D     |                               |                |
| 00                     | TRICON<br>ASSEMBLY            | Inspect                        |                          | 0.3 | 0.3               |                    |       | A                             |                |
|                        |                               | Repair                         |                          |     | 0.5               |                    |       | C                             |                |
|                        |                               | Clean                          |                          | 0.5 |                   |                    |       |                               |                |
|                        |                               | Paint                          |                          |     | 1.0               |                    |       | C                             |                |
| 01                     | CONTAINER,<br>WELDED          | Inspect                        |                          | 0.1 | 0.1               |                    |       | A                             |                |
|                        |                               | Repair                         |                          |     | 2.0               |                    |       | C                             |                |
| 02                     | SHELVES                       | Inspect                        | 0.2                      |     |                   |                    |       | A                             |                |
|                        |                               | Replace                        | 0.1                      |     |                   |                    |       | B                             |                |
| 03                     | SUPPORT<br>BEAMS              | Inspect                        | 0.1                      |     |                   |                    |       | A                             |                |
|                        |                               | Replace                        | 0.1                      |     |                   |                    |       | B                             |                |
| 04                     | CONNECTING<br>LINK ASSEMBLY   | Inspect                        | 0.1                      |     |                   |                    |       | A                             |                |
|                        |                               | Replace                        | 0.1                      |     |                   |                    |       | B                             |                |
| 05                     | DOCUMENT<br>HOLDER            | Inspect                        |                          | 0.4 |                   |                    |       | A                             |                |
|                        |                               | Replace                        |                          | 1.0 |                   |                    |       |                               |                |
|                        |                               | Paint                          |                          | 1.0 |                   |                    |       | C                             |                |
| 06                     | VENTS                         | Inspect                        |                          |     | 0.5               |                    |       | A                             |                |
|                        |                               | Replace                        |                          |     | 1.0               |                    |       |                               |                |
|                        |                               | Paint                          |                          |     | 1.0               |                    |       | C                             |                |
| 07                     | DOOR SEALS                    | Inspect                        |                          |     | 0.5               |                    |       | A                             |                |
|                        |                               | Replace                        |                          |     | 1.0               |                    |       |                               |                |



**SECTION III. TOOL AND TEST EQUIPMENT REQUIREMENTS  
FOR  
TRICON ASSEMBLY**

| <b>Tool-or Test<br/>Equipment<br/>REF Code</b> | <b>Maintenance<br/>Level</b> | <b>Nomenclature</b> | <b>National<br/>NATO Stock<br/>Number</b> | <b>Tool<br/>Number</b> |
|--|------------------------------|---------------------|---|------------------------|
| 1  | F                            | Hand Drill          |   |                        |
| 2  | F                            | Hand Grinder        |   |                        |
| 3  | O                            | Caulk Gun           |   |                        |
| 4  | F                            | Rivet Tool          |   |                        |
| 5  | O                            | Socket Wrench Set   |   |                        |
| 6  | O                            | Slings              |   |                        |

**SECTION IV. REMARKS**

| <b>Reference<br/>Code</b> | <b>Remarks</b>   |
|---------------------------|--|
| A                         | External and internal visual and mechanical inspection.  |
| B                         | Repair including replacement of assemblies: shelves, brackets and connecting link assemblies.      |
| C                         | Repair by patching and welding using procedures in TC 9-237. Paint using procedures in TM 43-0139. |

**APPENDIX C**  
**ORGANIZATIONAL, DIRECT SUPPORT, AND**  
**GENERAL SUPPORT MAINTENANCE**  
**REPAIR PARTS AND SPECIAL TOOLS LIST**

**SECTION I. INTRODUCTION**

**C-1 SCOPE.**

This RPSTL lists and authorizes spares and repair parts; special tools; special test, measurement, and diagnostic equipment (TMDE); and other special support equipment required for performance of organizational, direct support, and general support maintenance of the Tricon Container. It authorizes the requisitioning, issue, and disposition of spares, repair parts and special tools as indicated by the source, maintenance and recoverability (SMR) codes.

**C-2 GENERAL.**

In addition to Section I, Introduction, this Repair Parts and Special Tools List is divided into the following sections:

C-2.1 Section II - Repair Parts List. A list of spares and repair parts authorized by this RPSTL for use in the performance of maintenance. The list also includes parts which must be removed for replacement of the authorized parts. Parts lists are composed of functional groups in ascending alphanumeric sequence, with the parts in each group listed in ascending figure and item number sequence. Bulk materials are listed by item name in FIG BULK at the end of the section. Repair parts kits or sets are listed separately in their own functional group within Section II. Repair parts for repairable special tools are also listed in the section.

C-2.2 Section III - Special Tools List. A list of special tools, special TMDE, and other special support equipment authorized by this RPS'I'L (as indicated by Basis of Issue (BOI) information in DESCRIPTION AND USABLE ON CODE (UOC) column) for the performance of maintenance.

C-2.3 Section IV - National Stock Number and Part Number Index. A list, in National item identification number (NIIN) sequence, of all National stock numbered items appearing in the listings, followed by a list in alphanumeric sequence of all part numbers appearing in the listing. National stock numbers and part numbers are cross-referenced to each illustration figure and item number appearance.

**C-3 EXPLANATION OF COLUMNS (SECTIONS II AND III).**

C-3.1 ITEM NO. (Column (1)). Indicates the number used to identify items called out in the illustration.

C-3.2 SMR CODE (Column (2)). The Source, Maintenance, and Recoverability (SMR) code is a 5-position code containing supply/requisitioning information, maintenance category authorization criteria, and disposition instruction, as shown in the following breakout:

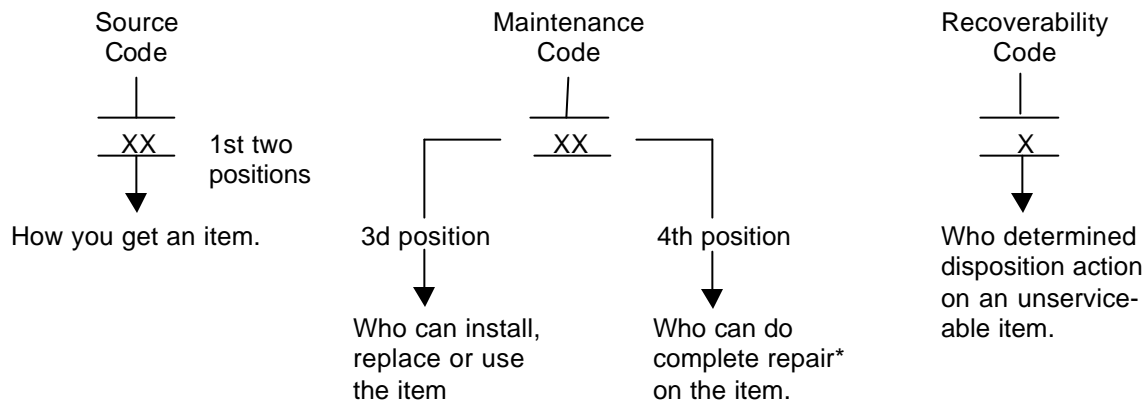

\*Complete Repair: Maintenance capacity, capability, and authority to perform all corrective maintenance tasks of the "Repair" function in a use/user environment in order to restore serviceability to a failed item.

a. Source Code. The source code tells you how to get an item needed for maintenance, repair, or overhaul of an end item/equipment. Explanations of source codes follow:

| Code                                     | Explanation  |
|--|--|
| PA<br>PB<br>PC**<br>PD<br>PE<br>PF<br>PG | Stocked items; use the applicable NSN to request/requisition items with these source codes. They are authorized to the category indicated by the code entered in the 3rd position of the SMR code. |
|  |  |

**\*\*NOTE: Items coded PC are subject to deterioration.**

|                |  |
|----------------|--|
| KD<br>KF<br>BK | Items with these codes are not to be requested/requisitioned individually. They are part of a kit which is authorized to the maintenance category indicated in the 3rd position of the SMR code. The complete kit must be requisitioned and applied. |
|----------------|--|

|  |   |
|--|---|
| MO- (Made at org/<br>AVUM Level)<br>MF- (Made at DS/<br>AVUM Level)<br>MH- (Made at GS<br>Level)<br>ML- (Made at<br>Specialized<br>Repair Act<br>(SRA))<br>MD- (Made at Depot) | Items with these codes are not to be requested/requisitioned individually. They must be made from bulk material which is identified by the part number in the DESCRIPTION AND USABLE ON CODE (UOC) column and listed in the Bulk Material group of the repair parts list in this RPSTL. If the item is authorized to you by the 3rd position code of the SMR code, but the source code indicates it is made at a higher level, order the item from the higher level of maintenance. |
|--|---|

| Code   | Explanation   |
|--|---|
| AO - (Assembled by org/<br>AVUM Level)<br>AF - (Assembled by DS/<br>AVIM Level)<br>AH - (Assembled by GS<br>Category)<br>AL - (Assembled by SRA)<br>AD - (Assembled by De-<br>pot) | Items with these codes are not to be requested/requisitioned individually. The parts that make up the assembled item must be requisitioned or fabricated and assembled at the level of maintenance indicated by the source code. If the 3rd position code of the SMR code authorizes you to replace the item, but the source code indicates the item is assembled at a higher level, order the item from the higher level of maintenance. |

- XA - Do no requisition an 'XA'-coded item. Order its next higher assembly. (Also, refer to the NOTE below.)
- XB - If an "XB" item is not available from salvage, order it using the FSCM and part number given.
- XC - Installation drawing, diagram, instruction sheet, field service drawing, that is identified by manufacturer's part number.
- XD - Item is not stocked. Order an "XD"-coded item through normal supply channels using the FSCM and part number given, if no NSN is available.

**NOTE: Cannibalization or controlled exchange, when authorized, may be used as a source of supply for items with the above source codes, except for those source coded "XA" or those aircraft support items restricted by requirements of AR 700-42.**

b. Maintenance Code. Maintenance codes tell you the level(s) of maintenance authorized to USE and REPAIR support items. The maintenance codes are entered in the third and fourth positions of the SMR Code as follows:

- (1) The maintenance code entered in the third position tells you the lowest maintenance level authorized to remove, replace, and use an item. The maintenance code entered in the third position will indicate authorization to one of the following levels of maintenance.

| Code | Application/Explanation   |
|------|---|
| C    | - Crew or operator maintenance done within organizational or aviation unit maintenance. |
| O    | - Organizational or aviation unit category can remove, replace, and use the item.       |
| F    | - Direct support or aviation intermediate level can remove, replace, and use the item.  |
| H    | - General support level can remove, replace, and use the item.                          |
| L    | - Specialized repair activity can remove, replace, and use the item.                    |
| D    | - Depot level can remove, replace, and use the item.                                    |

- (2) The maintenance code entered in the fourth position tells whether or not the item is to be repaired and identifies the lowest maintenance level with the capability to do complete repair (i.e., perform all authorized repair functions). (NOTE: Some limited repair may be done on the item at a lower level of maintenance, if authorized by the Maintenance Allocation Chart (MAC) and SMR codes.) This position will contain one of the following maintenance codes.

| Code | Application/Explanation   |
|------|---|
| O    | - Organizational or (aviation unit) is the lowest level that can do complete repair of the item.  |
| F    | - Direct support or aviation intermediate is the lowest level that can do complete repair of the item.  |
| H    | - General support is the lowest level that can do complete repair of the item.  |
| L    | - Specialized repair activity (designate the specialized repair activity) is the lowest level that can do complete repair of the item.  |
| D    | - Depot is the lowest level that can do complete repair of the item.  |
| Z    | - Nonrepairable. No repair is authorized.   |
| B    | - No repair is authorized. (No parts or special tools are authorized for the maintenance of a "B" coded item.) However, the item may be reconditioned by adjusting, lubricating, etc., at the user level. |

- c. Recoverability Code. Recoverability codes are assigned to items to indicate the disposition action on unserviceable items. The recoverability code is entered in the fifth position of the SMR Code as follows:

| Recoverability Codes | Application/Explanation   |
|----------------------|---|
| Z                    | - Nonrepairable item. When unserviceable, condemn and dispose of the item at the level of maintenance shown in 3rd position of SMR Code.  |
| O                    | - Repairable item. When uneconomically repairable, condemn and dispose of the item at organizational or aviation unit level.  |
| F                    | - Repairable item. When uneconomically repairable, condemn and dispose of the item at the direct support or aviation intermediate level.  |
| H                    | - Repairable item. When uneconomically repairable, condemn and dispose of the item at the general support level.  |
| D                    | - Repairable item. When beyond lower level repair capability, return to depot. Condemnation and disposal of item not authorized below depot level.  |
| L                    | - Repairable item. Condemnation and disposal not authorized below specialized repair activity (SRA).  |
| A                    | - Item requires special handling or condemnation procedures because of specific reasons (e.g., precious metal content, high dollar value, critical material, or hazardous material). Refer to appropriate manuals/directives for specific instructions. |

C-3.3 FSCM (Column (3)). The Federal Supply Code for Manufacturer (FSCM) is a 5-digit numeric code which is used to identify the manufacturer, distributor, or Government agency, etc., that supplies the item.

C-3.4 PART NUMBER (Column (4)). Indicates the primary number used by the manufacturer (individual, company, firm, corporation, or Government activity), which controls the design and characteristics of the item by means of its engineering drawings, specifications standards, and inspection requirements to identify an item or range of items.

**NOTE: When you use an NSN to requisition an item, the item you receive may have a different part number from the part ordered.**

C-3.5 DESCRIPTION AND USABLE ON CODE (UOC) (Column (5)). This column includes the following information:

- a. The Federal item name and, when required, a minimum description to identify the item.
- b. The physical security classification of the item is indicated by the parenthetical entry (insert applicable physical security classification abbreviation, e.g., Phy Sec C1 (C) -Confidential, Phy Sec C1 (S) -Secret, Phy Sec C1 (T) Top Secret).
- c. Items that are included in kits and sets are listed below the name of the kit or set.
- d. Spare/repair parts that make up an assembled item are listed immediately following the assembled item line entry.
- e. Part numbers for bulk materials are referenced in this column in the line item entry for the item to be manufactured/fabricated.
- f. When the item is not used with all serial numbers of the same model, the effective serial numbers are shown on the last line(s) of the description (before UOC).
- g. The usable on code, when applicable (see paragraph 5, Special information).
- h. In the Special Tools List section, the basis of issue (BOI) appears as the last line(s) in the entry for each special tool, special TMDE, and other special support equipment. When density of equipments supported exceeds density spread indicated in the basis of issue, the total authorization is increased proportionately.
- i. The statement "END OF FIGURE" appears just below the last item description in Column 5 for a given figure in both Section II and Section III.

C-3.6 QTY (Column (6)). The QTY (quantity per figure column) indicates the quantity of the item used in the breakout shown on the illustration figure, which is prepared for a functional group, subfunctional group, or an assembly. A "V" appearing in this column in lieu of a quantity indicates that the quantity is variable and the quantity may vary from application to application.

**C-4 EXPLANATION OF COLUMNS (SECTION IV).**

C-4.1 NATIONAL STOCK NUMBER (NSN) INDEX

- a. STOCK NUMBER column. This column lists the NSN by National item identification number (NIIN) sequence.

NSN

The NIIN consists of the last nine digits of the NSN (i.e., 5305-01-674-1467)- When using this column

NIIN

to locate an item, ignore the first 4 digits of the NSN. However, the complete NSN should be used when ordering items by stock number.

- b. FIG. column. This column lists the number of the figure where the item is identified/located. The figures are in numerical order in Section II and Section III.
- c. ITEM column. The item number identifies the item associated with the figure listed in the adjacent FIG. column. This item is also identified by the NSN listed on the same line.

C-4.2 PART NUMBER INDEX. Part numbers in this index are listed by part number in ascending alphanumeric sequence (i.e., vertical arrangement of letter and number combination which places the first letter or digit of each group in order A through Z, followed by the numbers 0 through 9 and each following letter or digit in like order).

- a. FSCM column. The Federal Supply Code for Manufacturer (FSCM) is a 5-digit numeric code used to identify the manufacturer, distributor, or Government agency, etc., that supplies the item.
- b. PART NUMBER column. Indicates the primary number used by the manufacturer (individual, firm, corporation, or Government activity), which controls the design and characteristics of the item by means of its engineering drawings, specifications standards, and inspection requirements to identify an item or range of items.
- c. STOCK NUMBER column. This column lists the NSN for the associated part number and manufacturer identified in the PART NUMBER and FSCM columns to the left.
- d. FIG. column. This column lists the number of the figure where the item is identified/located in Sections II and III.
- e. ITEM column. The item number is that number assigned to the item as it appears in the figure referenced in the adjacent figure number column.

**C-5 SPECIAL INFORMATION.**

The usable on code appears in the lower left corner of the Description column heading. Usable on codes are shown as "UOC: ..... "in the Description Column (justified left) on the first line of the applicable item description/nomenclature. Uncoded items are applicable to all models. Identification of the usable on codes used in the RPSTL are:

| <u>Code</u> | <u>Used On</u>               |
|-------------|------------------------------|
| None used.  | Not applicable at this time. |

**C-6 HOW TO LOCATE REPAIR PARTS.**

C-6.1 When National Stock Number or Part Number is Not Known.

- a. First. Using the table of contents, determine the assembly group or subassembly group to which the item belongs. This is necessary since figures are prepared for assembly groups and subassembly groups, and listings are divided into the same groups.
- b. Second. Find the figure covering the assembly group or subassembly group to which the item belongs.

- c. Third. Identify the item on the figure and note the item number.
- d. Fourth. Refer to the Repair Parts List for the figure to find the part number for the item number noted on the figure.
- e. Fifth. Refer to the Part Number Index to find the NSN, if assigned.

C-6.2 When National Stock Number or Part Number is Known.

- a. First. Using the Index of National Stock Numbers and Part Numbers, find the pertinent National Stock Number or Part Number. The NSN index is in National Item Identification Number (NIIN) sequence (see C-4.1). The part numbers in the Part Number index are listed in ascending alphanumeric sequence (see C-4.2). Both indexes cross-reference you to the illustration figure and item number of the item you are looking for.
- b. Second. After finding the figure and item number, verify that the item is the one you're looking for, then locate the item number in the repair parts list for the figure.

Abbreviations

NIIN

RPSTL

Explanation

National Item Identification Number (consists of the last 9 digits of the NSN)

Repair Parts and Special Tools List

SECTION II. REPAIR PARTS LIST

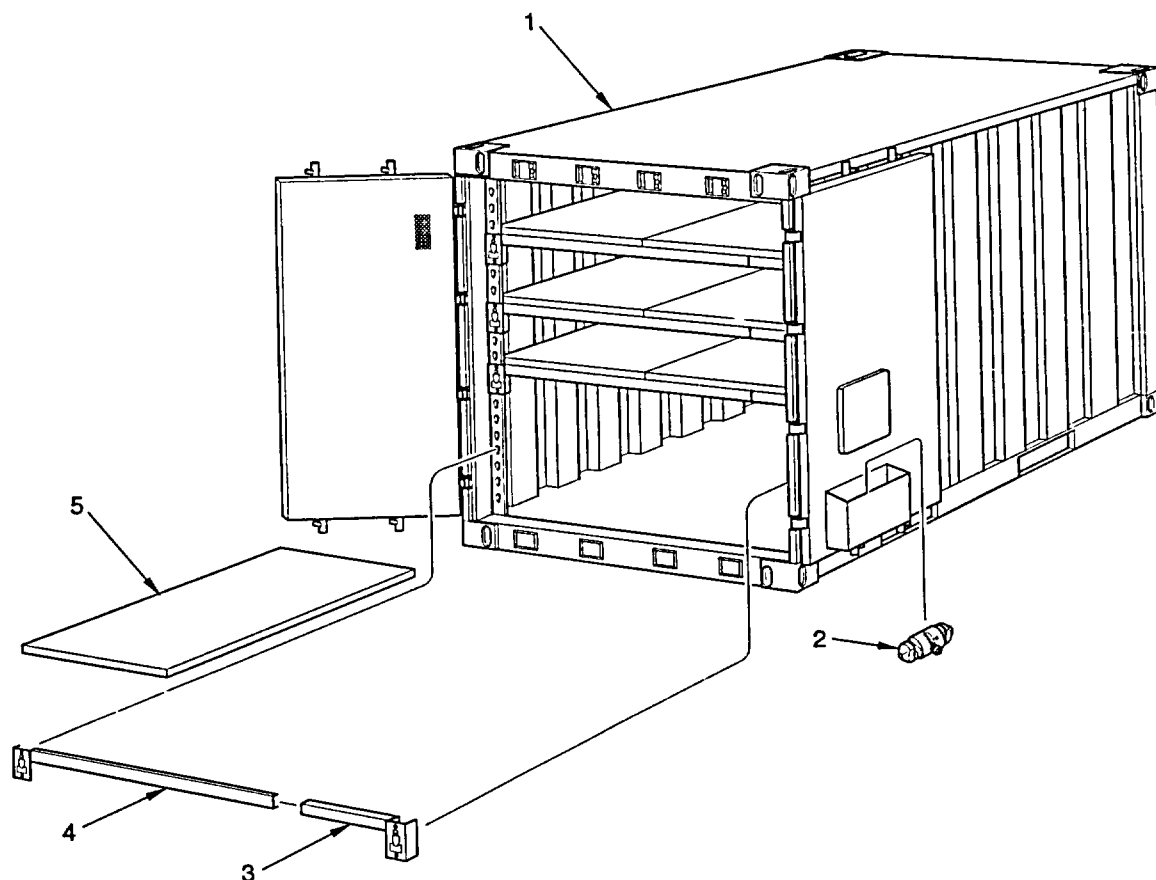

Figure C-1. Tricon Container.

| (1)<br>ITEM<br>NO | (2)<br>SMR<br>CODE | (3)<br>CAGEC | (4)<br>PART<br>NUMBER | (5)<br>DESCRIPTION AND USABLE ON CODES (UOC)                                    | (6)<br>QTY |
|-------------------|--------------------|--------------|-----------------------|---|------------|
| 1                 | PAFFD              | OXGU7        | 8145-01-389-9184      | GROUPS 00 THROUGH 07<br>FIGURE C-1. TRICON CONTAINER.<br>TRICON CONTAINER ..... | 1          |
| 2                 | PAOZZ              | OXGU7        | 1103-000              | CONNECTING LINK ASSEMBLY .....  | 3          |
| 3                 | PAOZZ              | OXGU7        | 1106-000              | BEAM, SHELF SUPPORT, RIGHT-HAND .....   | 12         |
|                   |                    |              |                       | (Serial numbers TC0100262 and lower only)                                       |            |
| 4                 | PAOZZ              | OXGU7        | 1105-000              | BEAM, SHELF SUPPORT, LEFT-HAND .....  | 12         |
|                   |                    |              |                       | (Serial numbers TC0100262 and lower only)                                       |            |
| 5                 | PAOZZ              | OXGU7        | 1107-000              | SHELF, FORMED STEEL .....   | 8          |
|                   |                    |              |                       | (Serial numbers TC0100262 and lower only)                                       |            |
|                   |                    |              |                       | END OF FIGURE   |            |



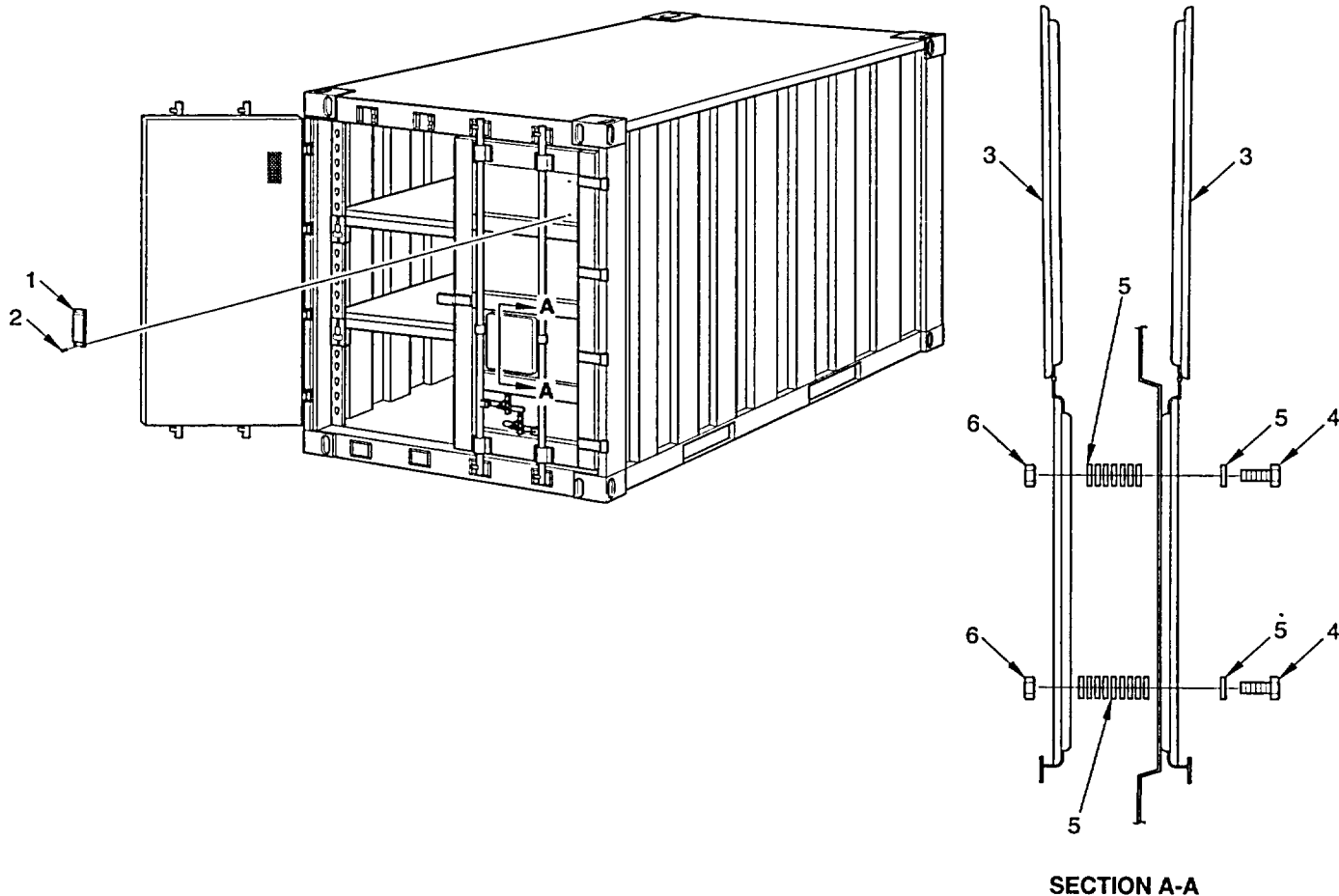

Figure C-2. Document Holder and Vent.

| (1)<br>ITEM<br>NO  | (2)<br>SMR<br>CODE | (3)<br>CAGEC | (4)<br>PART<br>NUMBER | (5)<br>DESCRIPTION AND USABLE ON CODES (UOC)         | (6)<br>QTY |
|--|--------------------|--------------|-----------------------|--|------------|
| GROUP 05 AND 06 FIGURE C-2. DOCUMENT HOLDER AND VENTILATORS. |                    |              |                       |  |            |
| 1  | PAFZZ              | OXGU7        | 1109-000              | VENTILATOR .....                                     | 4          |
| 2  | PAFZZ              | OXGU7        | 118-005               | RIVET, BUTTON-HEAD, 3/16 X 3/4 INCH, ST. STEEL ..... | 12         |
| 3  | PAOZZ              | OXGU7        | 100-000               | HOLDER, DOCUMENT .....                               | 2          |
| 4  | PAOZZ              | 96906        | MS35307-308           | SCREW HEX-HEAD, 1/4-20 X 1 INCH .....                | 4          |
| 5  | PAOZZ              | 96906        | MS15795-810           | WASHER, ROUND, 1/4 INCH .....                        | 36         |
| 6  | PAOZZ              | 96906        | MS51922-2             | NUT, SELF-LOCKING, 1/4-20 .....                      | 4          |
| END OF FIGURE  |                    |              |                       |  |            |

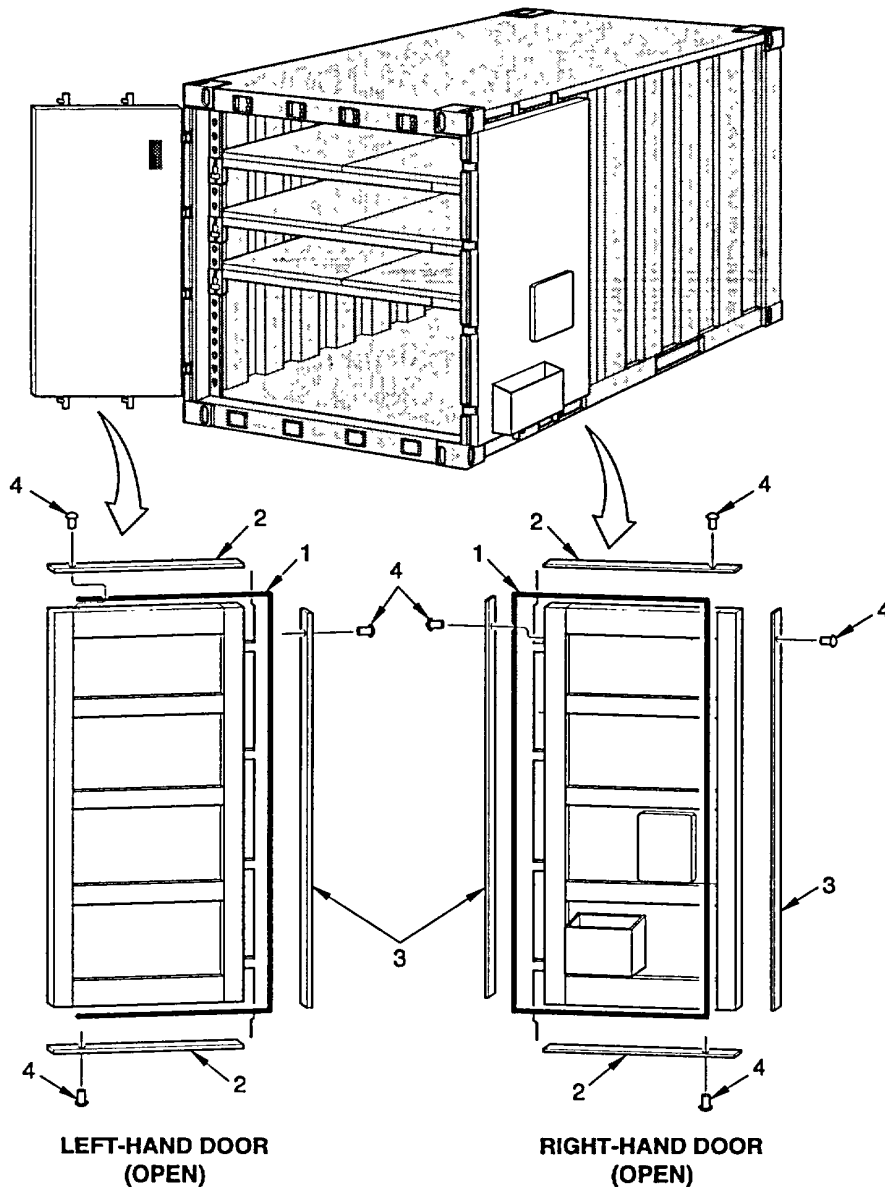

Figure C-3. Door Seals.

| (1)<br>ITEM<br>NO | (2)<br>SMR<br>CODE | (3)<br>CAGEC | (4)<br>PART<br>NUMBER | (5)<br>DESCRIPTION AND USABLE ON CODES (UOC)            | (6)<br>QTY |
|-------------------|--------------------|--------------|-----------------------|---|------------|
|                   |                    |              |                       | GROUP 07 FIGURE C-3. DOOR SEALS.                        |            |
| 1                 | PAFZZ              | OXGU7        | 303-000               | SET, SEALS .....  | 1          |
| 2                 | PAFZZ              | OXGU7        | 86-011                | CARRIER, SEAL, LONG .....                               | 3          |
| 3                 | PAFZZ              | OXGU7        | 115-008               | CARRIER, SEAL, SHORT .....                              | 4          |
| 4                 | PAFZZ              | OXGU7        | 118-005               | RIVET, BUTTON-HEAD, 3/16 X 3/4 INCH, ST.<br>STEEL ..... | 54         |
|                   |                    |              |                       | END OF FIGURE   |            |

**SECTION III. SPECIAL TOOLS LIST**

None Required.

**SECTION IV. NATIONAL STOCK NUMBER AND PART NUMBER INDEX**

| NATIONAL STOCK NUMBER INDEX |      |      |
|-----------------------------|------|------|
| STOCK NUMBER                | FIG. | ITEM |
| 8145-01-389-9184            | C-1  | 1    |

| PART NUMBER INDEX |             |                  |      |      |
|-------------------|-------------|------------------|------|------|
| FSCM              | PART NUMBER | STOCK NUMBER     | FIG. | ITEM |
| 96906             | MS15795-810 |                  | C-2  | 5    |
| 96906             | MS35307-308 |                  | C-2  | 4    |
| 96906             | MS51922-2   |                  | C-2  | 6    |
| OXGU7             | 100-000     |                  | C-2  | 3    |
| OXGU7             | 1103-000    |                  | C-1  | 2    |
| OXGU7             | 1105-000    |                  | C-1  | 4    |
| OXGU7             | 1106-000    |                  | C-1  | 3    |
| OXGU7             | 1107-000    |                  | C-1  | 5    |
| OXGU7             | 1109-000    |                  | C-2  | 1    |
| OXGU7             | 115-008     |                  | C-3  | 3    |
| OXGU7             | 118-005     |                  | C-2  | 2    |
|                   |             |                  | C-3  | 4    |
| OXGU7             | 303-000     |                  | C-3  | 1    |
| OXGU7             |             | 8145-01-389-9184 | C-1  | 1    |
| OXGU7             | 86-011      |                  | C-3  | 2    |

## APPENDIX D

## COMPONENTS OF END ITEM AND BASIC ISSUE ITEMS LISTS

## SECTION I. INTRODUCTION

**D-1 SCOPE.**

This appendix lists components of the end item and basic issue items for the Tricon container to help you inventory the items for safe and efficient operation of the equipment.

**D-2 GENERAL.**

The Components of End Item (COEI) and Basic Issue Items (BII) Lists are divided into the following sections:

- a. Section II, Components of End Item. This listing is for information purposes only, and is not authority to requisition replacements. These items are part of the Tricon container. As part of the end item, these items must be with the end item whenever it is issued or transferred between property accounts. Items of COEI are removed and separately packaged for transportation or shipment only when necessary. Illustrations are furnished to help you find and identify the items.
- b. Section III, Basic Issue Items. These essential items are required to place the Tricon container in operation, operate it, and to do emergency repairs. Although shipped separately packaged, BII must be with the Tricon container during operation and when it is transferred between property accounts. This list is your authority to request/requisition them for replacement based on authorization of the end item by the TOE/MTOE.

**D-3 EXPLANATION OF COLUMNS.**

- a. Column (1), Illus Number, gives you the number of the item illustrated.
- b. Column (2), National Stock Number, identifies the stock number of the item to be used for requisitioning purposes.
- c. Column (3), Description and Usable On Code, identifies the Federal item name (in all capital letters) followed by a minimum description when needed. The last line below the description is the Commercial and Government Entity Code (CAGEC) (in parentheses) and the part number.
- d. Column (4), U/I (unit of issue), indicates how the item is issued for the National Stock Number shown in column two.
- e. Column (5), Qty Rqd, indicates the quantity required.

SECTION II. COMPONENTS OF END ITEM

| (1)<br>Illus<br>Number | (2)<br>National Stock<br>Number | (3)<br>Description<br>CAGEC and Part Number | (4)<br>U/I | (5)<br>Qty<br>Rqd |
|------------------------|---------------------------------|---|------------|-------------------|
| 1                      | 8145-01-389-9184                | CONTAINER, TRICON<br>(OXGU7) ESE237-000     | EA         | 1                 |
| 2                      | --                              | CONNECTING LINK ASSEMBLY<br>(OXGU7)         | EA         | 3                 |

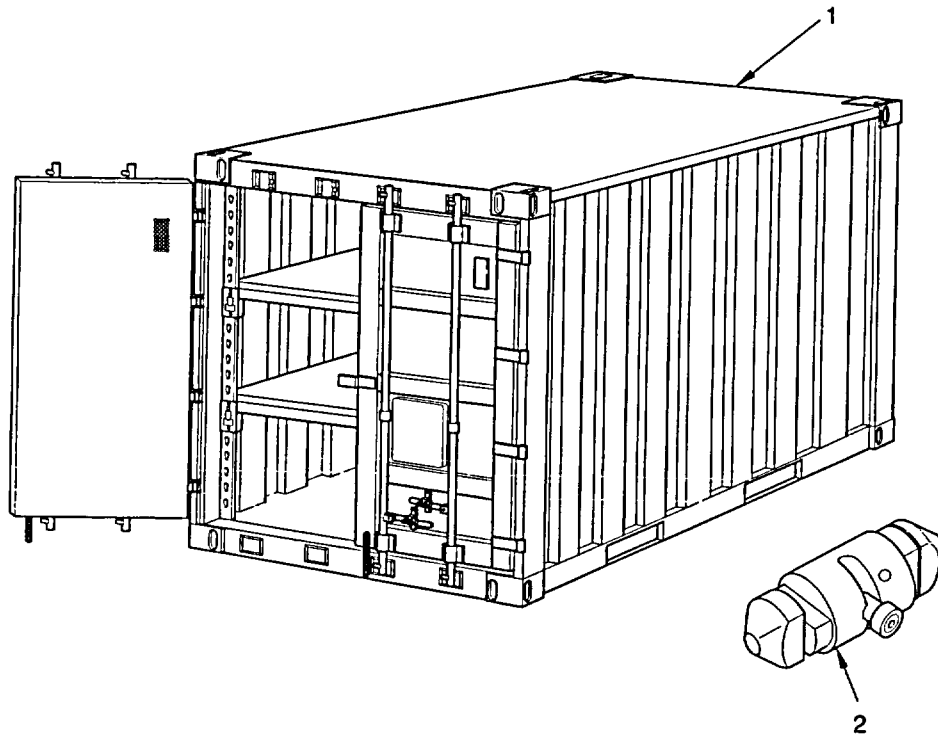

**SECTION III. BASIC ISSUE ITEMS**

| (1)<br>Illus<br>Number | (2)<br>National Stock<br>Number | (3)<br>Description<br>CAGEC and Part Number   | (4)<br>U/I | (5)<br>Qty<br>Rqd |
|------------------------|---------------------------------|---|------------|-------------------|
| --                     | TM 55-8145-203-13&P             | TECHNICAL MANUAL, Operator's Unit and Direct Support Maintenance Manual Including Repair Parts and Special Tools List (RPSTL) for Tricon container. | EA         | 1                 |

## APPENDIX E

## ADDITIONAL AUTHORIZATION LIST

## SECTION I. INTRODUCTION

**E-1 SCOPE.**

This appendix lists additional items that you are authorized for the support of Tricon Container.

**E-2 GENERAL.**

This list identifies items that do not have to accompany the Tricon Container and that do not have to be turned in with it. These items are authorized to you by CTA, MTOE, TDA or JTA.

**E-3 EXPLANATION OF LISTING.**

National Stock Numbers, description, and quantities are provided to help you identify and request the additional items you require to support this equipment. If the item required differs for different models of this equipment, see the "Used On Code" column for the applicable model for models. Codes used are:

| <u>Used on Code</u> | <u>Model</u> |
|---------------------|--------------|
| FKZ                 | ESETC-01     |

## SECTION II. ADDITIONAL AUTHORIZATION ITEMS LIST

## NOTE

**No authorized items have been identified.**

## APPENDIX F

## EXPENDABLE AND DURABLE ITEMS LIST

## SECTION I. INTRODUCTION

## F-1 SCOPE.

This appendix lists expendable and durable items that you will need to operate and maintain the Tricon Container. This listing is for information only and is not authority to requisition the listed items. These items are authorized to you by CTA 50-790, Expendable/Durable Items (except medical, Class V repair parts, and heraldic items), or CTA 8-100, Army Medical Department Expendable/Durable Items.

## F-2 EXPLANATION OF COLUMNS.

- a. Column 1. Item number. This number is assigned to the entry in the listing and is referenced in the narrative instructions to identify the item (e.g., apply bead of silicone (Item 1, Appendix F)).
- b. Column 2. Level. This column identifies the lowest level of maintenance that requires the item.
- c. Column 3. National stock number. This is the national stock number assigned to the item which you can use to requisition it.
- d. Column 4. Item name, description, Commercial and Government Entity Code (CAGEC), and part number. This provides the other information you need to identify the item.
- e. Column 5. Unit of measure. This code shows the physical measurement or count of an item, such as gallon, dozen, gross, etc.

## SECTION II. EXPENDABLE/DURABLE SUPPLIES AND REQUIREMENTS LIST

| (1)<br>Item<br>Number | (2)<br>Level | (3)<br>National<br>Stock<br>Number | (4)<br>Item Name, Description, CAGEC,<br>Part Number | (5)<br>U/M |
|-----------------------|--------------|------------------------------------|--|------------|
| 1                     | O            |                                    | Sealant, Silicon, Clear, Tube (5D028)<br>8641        | EA         |
| 2                     | F            |                                    | Sealant, Polyurethane, Tube (38650) 221              | EA         |



**APPENDIX G**  
**TORQUE LIMITS**

**G-1 SCOPE.**

Only one type of bolt/nut combination is used on the Tricon Container. The bolt is used to secure the document holders to the right-hand door. The maximum torque value is 2 ft•lbs.

## APPENDIX H

## MANDATORY REPLACEMENT PARTS

| <u>Fig/Item</u> | <u>Nomenclature</u> | <u>Part No.</u> |
|-----------------|---------------------|-----------------|
| C-2/2           | Rivet               | 118-005         |
| C-3/1           | Set, Seals          | 303-000         |
| C-3/2           | Carrier             | 86-011          |
| C-3/3           | Carrier             | 115-008         |

**APPENDIX I**

**ILLUSTRATED LIST OF MANUFACTURED ITEMS**

**NOTE**

**No items are required to be manufactured at the unit maintenance level.**

**GLOSSARY**

|                          |   |
|--------------------------|---|
| Carriers                 | Galvanized steel strips that are placed over the door seals. These strips add support so the nails or rivets do not tear the seals.   |
| Connecting Link Assembly | An assembly of machined parts that is used to connect Tricon Containers together. The ends of the assembly are inserted into the container corners and rotated. When properly rotated they lock the containers together.  |
| Lockrod Assembly         | Metal rod attached to the door in the vertical plane. The ends of the assembly have tabs that engage fixtures that lock the rod, and the door, in place. Each door has two lockrod assemblies.  |
| Shelf Support Beams      | Horizontal beams that support the shelves. The support beams have manually actuated locking devices that allow the beams to be adjusted up or down. Rivets on the support beams insert into teardrop-shaped cutouts on the vertical shelf supports to position the beams. |
| Vertical Shelf Support   | Angled pieces of track welded to the container sides. Rivets on the support beams are inserted into teardrop-shaped cutouts running up and down on the tracks.  |

INDEX

| Subject  | Paragraph     |
|--|---------------|
| <b>C</b>   |               |
| Connecting Link Assembly                                   |               |
| Purpose .....  | 1.13.3.2.1    |
| Replace.....   | 3.10          |
| Use of (See Operation, Coupling and Uncoupling Containers) |               |
| <b>D</b>   |               |
| Document Holders   |               |
| Damage to.....   | 3.7           |
| Inspection .....   | 4.5           |
| Replace.....   | 4.8           |
| Doors  |               |
| Closing the Doors .....                                    | 2.10          |
| Door Seals/Replacement .....                               | 5.14          |
| Opening Doors .....  | 2.7           |
| <b>L</b>   |               |
| Lifting Containers   |               |
| Coupled Containers .....                                   | 2.14          |
| Single Container .....                                     | 2.13          |
| Using Forklift .....                                       | 2.13.3,2.14.3 |
| Lubrication.....   | 3.1, 4.1, 5.1 |
| <b>O</b>   |               |
| Operation  |               |
| Closing (see Doors)  |               |
| Coupling Containers.....                                   | 2.11          |
| Loading .....  | 2.9           |
| Opening (see Doors)  |               |
| Principles .....   | 1.16          |
| Uncoupling Containers .....                                | 2.12          |
| <b>P</b>   |               |
| Painting.....  | 5.20          |
| <b>S</b>   |               |
| Shelf (Shelves)  |               |
| Adjusting .....  | 2.8           |
| Description .....  | 1.10          |
| Inspection .....   | 2.4, 4.5, 5.5 |
| Replacing.....   | 3.9           |
| <b>W</b>   |               |
| Welding .....  | 5.17, 5.18    |

**By Order of the Secretary of the Army:**

Official:

DENNIS J. REIMER  
*General, United States Army*  
*Chief of Staff*

JOEL B. HUDSON  
*Administrative Assistant to the*  
*Secretary of the Army*  
03147

**DISTRIBUTION:**

To be distributed in accordance with DA Form 12-25-E, block no. 6423, requirements for TM 55-8145-203-13&P.

## These are the instructions for sending an electronic 2028

The following format must be used if submitting an electronic 2028. The subject line must be exactly the same and all fields must be included; however only the following fields are mandatory: 1, 3, 4, 5, 6, 7, 8, 9, 10, 13, 15, 16, 17, and 27.

From: "Whomever" <whomever@avma27.army.mil>  
To: mpmt%avma28@st-louis-emh7.army.mil

Subject: DA Form 2028

1. **From:** Joe Smith
2. *Unit:* home
3. **Address:** 4300 Park
4. **City:** Hometown
5. **St:** MO
6. **Zip:** 77777
7. **Date Sent:** 19-OCT-93
8. **Pub no:** 55-2840-229-23
9. **Pub Title:** TM
10. **Publication Date:** 04-JUL-85
11. *Change Number:* 7
12. *Submitter Rank:* MSG
13. **Submitter FName:** Joe
14. *Submitter MName:* T
15. **Submitter LName:** Smith
16. **Submitter Phone:** 123-123-1234
17. **Problem:** 1
18. *Page:* 2
19. *Paragraph:* 3
20. *Line:* 4
21. *NSN:* 5
22. *Reference:* 6
23. *Figure:* 7
24. *Table:* 8
25. *Item:* 9
26. *Total:* 123
27. **Text:**

This is the text for the problem below line 27.

RECOMMENDED CHANGES TO EQUIPMENT TECHNICAL PUBLICATIONS



THEN . . . JOT DOWN THE DOPE ABOUT IT ON THIS FORM, CAREFULLY TEAR IT OUT, FOLD IT AND DROP IT IN THE MAIL!

SOMETHING WRONG WITH THIS PUBLICATION?

FROM: (PRINT YOUR UNIT'S COMPLETE ADDRESS)

PFC John DOE  
 Co A 3rd Engineer Bn  
 Ft. Leonardwood, MO 63108

DATE SENT

22 August 1992

PUBLICATION NUMBER

TM 1-1520-250-10

PUBLICATION DATE

15 June 1992

PUBLICATION TITLE

Operator's manual MH60K Helicopter

BE EXACT PIN-POINT WHERE IT IS

IN THIS SPACE, TELL WHAT IS WRONG AND WHAT SHOULD BE DONE ABOUT IT:

| PAGE NO | PARA-GRAPH | FIGURE NO | TABLE NO |
|---------|------------|-----------|----------|
| 6       | 2-1<br>a   |           |          |
| B1      |            | 4-3       |          |

In line 6 of paragraph 2-1a the manual states the engine has 6 cylinders. The engine on my set only has 4 cylinders. Change the manual to show 4 cylinders.

Callout 16 in figure 4-3 is pointed at a bolt. In key to figure 4-3, item 16 is called a shim. Please correct one or the other

PRINTED NAME, GRADE OR TITLE, AND TELEPHONE NUMBER

JOHN DOE, PFC (268) 317-7111

SIGN HERE

JOHN DOE *John Doe*

DA FORM 2028-2  
 1 JUL 79

PREVIOUS EDITIONS ARE OBSOLETE.  
 DRSTS-M verprint2, 1 Nov 80

P.S. - IF YOUR OUTFIT WANTS TO KNOW ABOUT YOUR RECOMMENDATION, MAKE A CARBON COPY OF THIS AND GIVE TO YOUR HEADQUARTERS.





FILL IN YOUR  
UNITS ADDRESS



FOLD BACK

DEPARTMENT OF THE ARMY

---

---

OFFICIAL BUSINESS

COMMANDER  
U.S. ARMY AVIATION AND TROOP COMMAND  
ATTN: AMSAT-I-MP  
4300 GOODFELLOW BOULEVARD  
ST. LOUIS, MO 63120-1798

TEAR ALONG PERFORATED LINE

## The Metric System and Equivalents

### **Linear Measure**

1 centimeter = 10 millimeters = .39 inch  
 1 decimeter = 10 centimeters = 3.94 inches  
 1 meter = 10 decimeters = 39.37 inches  
 1 dekameter = 10 meters = 32.8 feet  
 1 hectometer = 10 dekameters = 328.08 feet  
 1 kilometer = 10 hectometers = 3.280.8 feet

### **Weights**

1 centigram = 10 milligrams = .15 grain  
 1 decigram = 10 centigrams = 1.54 grains  
 1 gram = 10 decigrams = .035 ounce  
 1 dekagram = 10 grams = .35 ounce  
 1 hectogram = 10 dekagrams = 3.52 ounces  
 1 kilogram = 10 hectograms = 2.2 pounds  
 1 quintal = 100 kilograms = 220.46 pounds  
 1 metric ton = 10 quintals = 1.1 short tons

### **Liquid Measure**

1 centiliter = 10 milliliters = .34 fl. ounce  
 1 deciliter = 10 centiliters = 3.38 fl. ounces  
 1 liter = 10 deciliters = 33.81 fl. ounces  
 1 dekaliter = 10 liters = 2.64 gallons  
 1 hectoliter = 10 dekaliters = 26.42 gallons  
 1 kiloliter = 10 hectoliters = 264.18 gallons

### **Square Measure**

1 sq. centimeter = 100 sq. millimeters = .155 sq. inch  
 1 sq. decimeter = 100 sq. centimeters = 15.5 sq. inches  
 1 sq. meter (centare) = 100 sq. decimeters = 10.76 sq. feet  
 1 sq. dekameter (are) = 100 sq. meters = 1.076.4 sq. feet  
 1 sq. hectometer (hectare) = 100 sq. dekameters = 2.47 acres  
 1 sq. kilometer = 100 sq. hectometers = .386 sq. mile

### **Cubic Measure**

1 cu. centimeter = 1000 cu. millimeters = .06 cu. inch  
 1 cu. decimeter = 1000 cu. centimeters = 61.02 cu. inches  
 1 cu. meter = 1000 cu. decimeters = 35.31 feet

## Approximate Conversion Factors

| <i>To change</i> | <i>To</i>          | <i>Multiply by</i> | <i>To change</i>   | <i>To</i>     | <i>Multiply by</i> |
|------------------|--------------------|--------------------|--------------------|---------------|--------------------|
| inches           | centimeters        | 2.540              | ounce-inches       | newton-meters | .007062            |
| feet             | meters             | .305               | centimeters        | inches        | .394               |
| yards            | meters             | .914               | meters             | feet          | 3.280              |
| miles            | kilometers         | 1.609              | meters             | yards         | 1.094              |
| square inches    | square centimeters | 6.451              | kilometers         | miles         | .621               |
| square feet      | square meters      | .093               | square centimeters | square inches | .155               |
| square yards     | square meters      | .836               | square meters      | square feet   | 10.764             |
| square miles     | square kilometers  | 2.590              | square meters      | square yards  | 1.196              |
| acres            | square hectometers | .405               | square kilometers  | square miles  | .386               |
| cubic feet       | cubic meters       | .028               | square hectometers | acres         | 2.471              |
| cubic yards      | cubic meters       | .765               | cubic meters       | cubic feet    | 35.315             |
| fluid ounces     | milliliters        | 29.573             | cubic meters       | cubic yards   | 1.308              |
| pints            | liters             | .473               | milliliters        | fluid ounces  | .034               |
| quarts           | liters             | .946               | liters             | pints         | 2.113              |
| gallons          | liters             | 3.785              | liters             | quarts        | 1.057              |
| ounces           | grams              | 28.349             | liters             | gallons       | .264               |
| pounds           | kilograms          | .454               | grams              | ounces        | .035               |
| short tons       | metric tons        | .907               | kilograms          | pounds        | 2.205              |
| pound-feet       | newton-meters      | 1.356              | metric tons        | short tons    | 1.102              |
| pound-inches     | newton-meters      | .11296             |                    |               |                    |

## Temperature (Exact)

|    |             |                 |             |    |
|----|-------------|-----------------|-------------|----|
| °F | Fahrenheit  | 5/9 (after      | Celsius     | °C |
|    | temperature | subtracting 32) | temperature |    |

**PIN: 075267-000**